



DEXTER AXLE

www.dexteraxle.com

9,000 - 15,000 LBS. CAPACITY



OPERATION MAINTENANCE SERVICE MANUAL

Introduction

This manual is designed to provide information for you to understand, use, maintain, and service your trailer running gear system. Your axles are manufactured by Dexter Axle. Since 1960, Dexter's experience in the design, testing, and manufacturing of trailer axles has resulted in the most complete product line in the industry. The Dexter running gear system consists of axles, suspensions, and braking systems which are engineered to provide you the finest towing and stopping performance currently available today.

Two Dexter philosophies are at work to provide you the best product available and have enabled us to maintain our position of leadership. First, we operate on the theory that "there is always a better way" for a product to operate, to be manufactured, and/or to be serviced. We are constantly striving to find that better way.

Secondly, we maintain wall-to-wall production control so that all the major components of your running gear system are manufactured in Dexter facilities under our strict quality control standards. These manufactured components include axle beams, hubs, drums, spindles, and braking systems, as well as the components used in the attachment of the axle to the chassis. Dexter has the most complete, state-of-the-art manufacturing facilities which enable us to provide you, the trailer owner, with the finest product possible.

For all your running gear needs...

Look first to Dexter!

**Visit us online at
www.dexteraxle.com**



Introduction

Maintenance Schedule.....4
Important Safety Notice.....5
Getting Started - Setup and Adjustment.....5
Answers to Commonly Asked Questions6

Braking Systems - Electric

Electric Brakes.....8
Features10
 Self Adjusting Feature11
 Brake Controllers.....11
 How To Use Your Electric Brakes Properly12
 Trailer Wire Size Chart.....12
 Synchronizing Your Trailer Brakes13
General Maintenance - Electric Brakes14
 Brake Adjustment14
 Brake Cleaning and Inspection15
 Brake Lubrication15
Magnets16
Shoes and Linings17
Introduction to Troubleshooting.....18
Troubleshooting18
 Troubleshooting Chart - Electric19
 How to Measure Voltage21
 How to Measure Amperage.....21
Magnet Amperes Chart22

Braking Systems - Hydraulic

Hydraulic Brakes24
Hydraulic Drum Brake Operation.....25
 Duo-Servo25
 Uni-Servo26
 Self-Adjusting Mechanism for 12¼" Brakes26
Hydraulic Parking Brake Option26
Hydraulic Disc Brakes28
Electric/Hydraulic Actuation Systems.....29
Vacuum/Hydraulic29
Air/Hydraulic.....30
Introduction to Troubleshooting.....31
 Troubleshooting Chart - Hydraulic32
 Electric/Hydraulic Troubleshooting Guide.....34
General Maintenance - Hydraulic Brakes36
 Drum Brake Adjustment36
 Wheel Cylinders37
 Brake Lines37
 Shoes and Linings.....37
 Hardware.....38
 Instructions for 10-12K Hydraulic Disc Brakes38
Hydraulic Disc Brake Parts.....41

Braking Systems - Air

S-Cam Air Brakes.....42
 Operation.....42
Air Brake Components43
 Air Chambers43
 Spring Brake.....43
 Slack Adjusters.....44
 S-Cams44
 Brake Shoes.....45

| | |
|--|----|
| General Maintenance/Adjustment | 46 |
| Brake Component Lubrication | 46 |
| 12¼" Quick Change Brakes - PQ | 47 |
| Recommended Disassembly | 47 |
| Recommended Reassembly | 47 |
| Air Brake Automatic Slack Adjustment | 49 |
| Air Brake Manual Slack Adjustment | 50 |
| Introduction to Troubleshooting | 52 |
| Troubleshooting Chart - Air | 53 |
| Hubs/Drums/Bearings | |
| Hubs/Drums/Bearings | 55 |
| Hub Removal | 55 |
| Brake Drum Inspection | 55 |
| Bearing Inspection | 56 |
| Bearing Lubrication - Grease | 57 |
| Bearing Lubrication - Oil | 58 |
| Recommended Wheel Bearing Lubrication Specs | 58 |
| Seal Inspection and Replacement | 61 |
| Installation/Adjustment | 61 |
| Axle Installation | |
| Axle & Suspension Installation | 63 |
| Suspensions | |
| Suspension Systems | 64 |
| Slipper Leaf Springs | 64 |
| Inspection and Replacement | 65 |
| Suspension Replacement | 67 |
| Torflex® Suspension | 67 |
| Wheels and Tires | |
| Wheels | 69 |
| Wheel Selection | 69 |
| Torque Requirements | 70 |
| Wheel Torque Sequence Chart | 71 |
| Tires | 72 |
| Tire Wear Diagnostic Chart | 73 |
| Replacement Parts/Kits | |
| Fastener Torque Specifications | 74 |
| Bearing Replacement Chart | 75 |
| Seal Replacement Reference | 75 |
| Electric Brake Magnets | 75 |
| Brake Shoe Replacement Kits | 76 |
| Air Brake Shoe & Linings | 76 |
| Air Brake Repair Kits | 76 |
| Disc Brake Pad Kit | 76 |
| Disc Brake Caliper Repair Kit | 76 |
| Storage | |
| Storage Preparation | 77 |
| After Prolonged Storage - Inspection Procedure | 78 |
| Trip Preparation Checklist | 78 |
| Warranty | |
| Dexter Axle Limited Warranty | 80 |
| Axle Identification | |
| Axle Identification | 83 |





Maintenance Schedule

| Item | Function Required | Weekly | 3 Months or 3,000 Miles | 6 Months or 6,000 Miles | 12 Months or 12,000 Miles |
|----------------------------|--|--------------|----------------------------|----------------------------|------------------------------|
| Brakes | Test that they are operational. | At Every Use | | | |
| Brake Adjustment | Adjust to proper operating clearance. | | ● | | |
| Brake Magnets | Inspect for wear and current draw. | | | ● | |
| Brake Linings | Inspect for wear or contamination. | | | | ● |
| Brake Controller | Check for correct amperage and modulation. | | | ● | |
| Brake Cylinders | Check for leaks, sticking. | | | | ● |
| Brake Lines | Inspect for cracks, leaks, kinks. | | | | ● |
| Camshaft Bushings | Check for wear and breakage. | | | ● | |
| Anchor Pins and Rollers | Lubricate with approved grease. | | | ● | |
| Slack Adjuster Lubrication | Lubricate with approved grease. | | | ● | |
| Trailer Brake Wiring | Inspect wiring for bare spots, fray, etc. | | | | ● |
| Breakaway System | Check battery charge and switch operation. | At Every Use | | | |
| Hub/Drum | Inspect for abnormal wear or scoring. | | | | ● |
| Wheel Bearing and Cups | Inspect for corrosion or wear. Clean and repack. | | | | ● |
| Seals | Inspect for leakage. Replace if removed. | | | | ● |
| Springs | Inspect for wear, loss of arch. | | | | ● |
| Suspension Parts | Inspect for bending, loose fasteners and wear. | | | ● | |
| Hangers | Inspect welds. | | | | ● |
| Wheel Nuts and Bolts | Tighten to specified torque values. | | ● | | |
| Wheels | Inspect for cracks, dents, or distortion. | | | ● | |
| Tire Inflation Pressure | Inflate tires to mfg's specifications. | ● | | | |
| Tire Condition | Inspect for cuts, wear, bulging, etc. | | ● | | |

Introduction

Important Safety Notice

Appropriate service methods and repair procedures are essential for the safe, reliable operation of all running gear as well as the personal safety of the individual doing the work. This manual provides general directions for performing service and repair work with tested, effective techniques. Following these guidelines will help assure reliability.

There are numerous variations in procedures, techniques, tools, parts for servicing axles, as well as in the skill of the individual doing the work. This manual cannot possibly anticipate all such variations and provide advice or cautions as to each. Anyone who departs from the instructions provided in this manual must first establish that they neither compromise their personal safety nor the vehicle integrity by their choice of methods, tools, or parts.

Refer to your vehicle manufacturer's owners manual for additional procedures, techniques, and warnings prior to performing any maintenance or repairs.

CAUTION

This is the safety alert symbol. It is used to alert you to potential injury hazards. Obey all safety messages that follow this symbol to avoid possible injury or death.

Getting Started - Setup and Adjustment

For proper performance, all new axles should have the following checked at the specified intervals:

- **Wheel Nut Torque:** at 10, 25, and 50 miles
- **Brake Adjustment:** at 200 and 3,000 miles
- **Tire pressure:** to manufacturer's requirements
- **Brake synchronization:** set brake controller per controller manufacturer's directions





Answers to Commonly Asked Questions

Q: Why do my brakes and hubs get so hot?

A: Braking systems use friction to slow the vehicle and the energy used to retard the trailer is converted to heat. Dexter brakes are designed to operate up to extremely high temperatures during hard braking application. This heat is noticeable on the hub and drums and is to be normally expected on a properly functioning brake. If a brake is malfunctioning and running excessively hot, this can be noticed by smoking brakes or the paint burning off of the brake drum. If this occurs, refer to the brake troubleshooting diagram for your type of brake.

Q: Why do I have to adjust my brakes?

A: Brakes must be adjusted to compensate for the lining and drum wear that occurs during use of the braking system. Some brakes require manual adjustment to move the linings closer to the drum. Refer to the brake adjustment section for your style of brakes. Other brakes may have an automatic brake adjuster such as the automatic slack adjusters for air brakes.

Note: Prior to 10/96 electric and hydraulic self-adjusting brakes adjust only during hard, reverse stops. If your driving does not include these types of stops, you will have to manually adjust your brakes. Designs after 10/96 adjust both in forward and in reverse. Adjustment in reverse still requires hard stops, while adjustment in forward motion will occur through normal driving.

Q: My brake linings are cracked, do I have to replace them?

A: Usually, light cracking of the surface of a brake lining can be expected under normal use. This is not cause for replacement. However, if the lining is missing chunks, your brake linings or shoes will require replacement.

Q: Why do I have to torque the wheel nuts on my trailer and do not have to do so in my car?

A: The main reason is wheel capacity. Your entire car may weigh 3,000 lbs. which is spread over four wheels, while a 6,000 lb. trailer axle has 3,000 lbs. on a single tire and wheel. This places greater stress on the wheel/tire combination. The second reason is loading. Your car is designed to have the wheels track the arc of a turn, reducing side load on the tire and wheel. Trailers are subjected to harsh side loads, especially in double and triple axle configurations. These side loads work to flex the wheel which may cause the wheel to lose torque over time. Please follow the wheel usage instructions located later in this manual.

Q: Why can't I lock and slide my electric brakes?

A: On an unloaded trailer, you may be able to lock up your brakes if your electric brake controller is supplying full amperage to the brakes. When loaded to capacity, you may not be able to lock your brakes as electric brakes are designed to slow the trailer at a controlled rate, and not designed to lock up the wheels on a fully loaded trailer. Our brakes are designed to meet all applicable safety standards. All of our brakes will perform better after numerous burnish stops to seat the brake linings to the drums.

Q: I don't feel I have enough brakes or capacity on my axles. Can I easily upgrade?

A: Usually depending on the trailer configuration, you can upgrade your running gear to a higher capacity rating. We recommend consulting with the trailer manufacturer first before doing so.

Q: Can I change my brakes from electric to hydraulic or vice versa?

A: This can be done on most axle models. We recommend contacting the trailer manufacturer prior to changing your braking system to identify any potential problems.





Electric Brakes

The electric brakes on your trailer are similar to the drum brakes on your automobile. The basic difference is that your automotive brakes are actuated by hydraulic pressure while your electric trailer brakes are actuated by an electromagnet. With all of the brake components connected into the system, the brake should operate as follows (see electric brake assembly illustration):

When the electrical current is fed into the system by the controller, it flows through the electromagnets in the brakes. The high capacity electromagnets are energized and are attracted to the rotating armature surface of the drums which moves the actuating levers in the direction that the drums are turning.

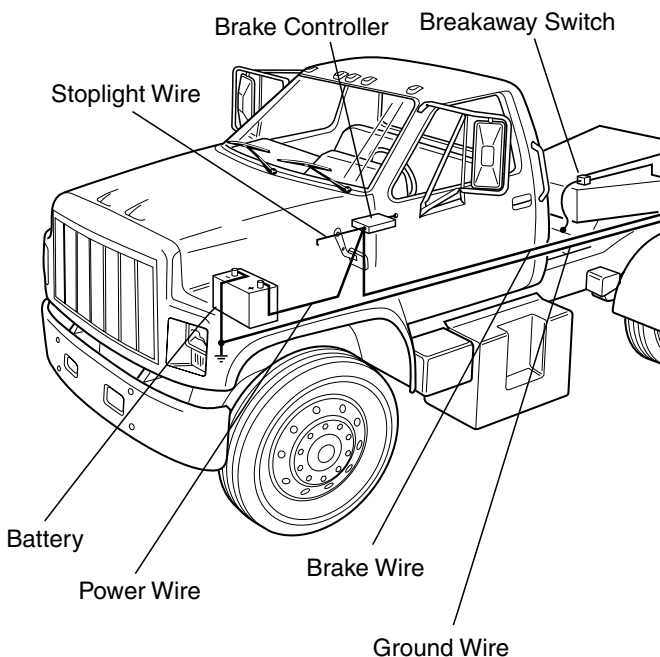

The resulting force causes the actuating cam block at the shoe end of the lever to push the primary shoe out against the inside surface of the brake drum. The force generated by the primary shoe acting through the adjuster link then moves the secondary shoe out into contact with the brake drum.

Increasing the current flow to the electromagnet causes the magnet to grip the armature surface of the brake drum more firmly. This results in increasing the pressure against the shoes and brake drums until the desired stop is accomplished.

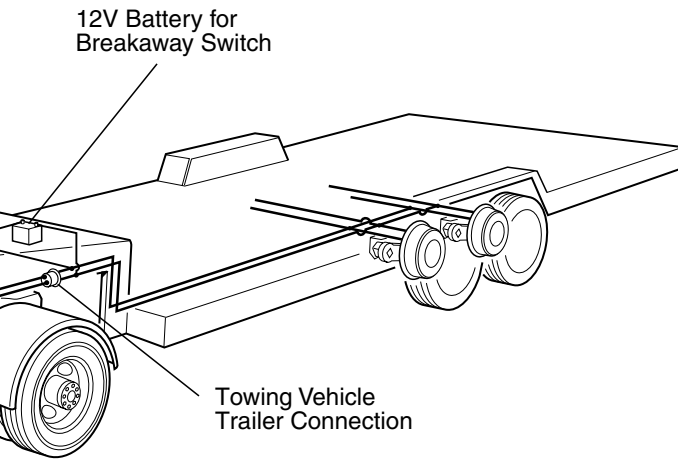



Features

Electrically actuated brakes have several advantages over other brake actuation systems.

1. They can be manually adjusted at the controller to provide the correct braking capability for varying road and load conditions.
2. They can be modulated to provide more or less braking force, thus easing the brake load on the towing vehicle.
3. They have very little lag time from the moment the tow vehicle's brakes are actuated until the trailer brakes are actuated.
4. In an emergency situation, they can provide some braking independent of the tow vehicle.

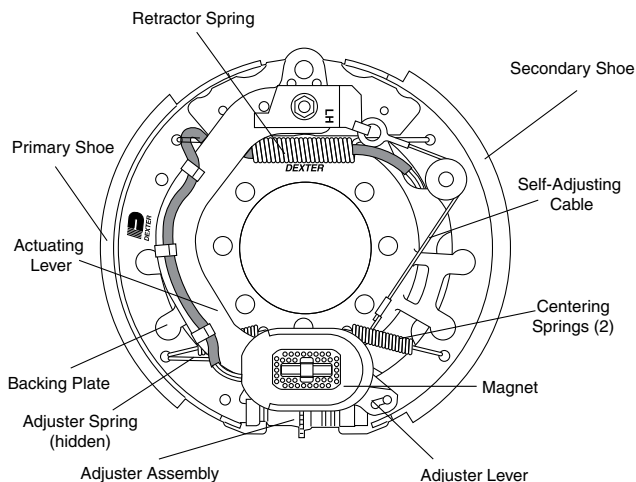

Left Hand or Road Side Brake Shown

Note: Actuating lever should always wrap around front side of axle, magnet wires should exit brake backing plate on rear side of axle.

Self Adjusting Feature (12¼" Brake Series Only)

Forward self adjust electric brakes were introduced in October of 1996. This feature adjusts the brakes on both forward and reverse stops. Brake adjustment occurs when lining wear results in enough gap between the shoes and the brake drum surface. This added clearance will allow the adjuster mechanism to rotate the screw assembly at the bottom of the brake. That action expands the distance between the shoes and thus closes the gap to the drum surface.

Brake Controllers

Electric brake controllers provide power to the magnets to actuate the trailer brakes. Dexter Axle offers a state-of-the-art inertial controller called the Predator DX2™. This controller features an accelerometer design which senses the deceleration of the towing vehicle and sends a proportional voltage to the electric trailer brakes. Other features include a visual gain setting for quick and easy adjustment and a digital LED display to show the voltage output. A manual override sends full voltage to the trailer brakes, regardless of gain setting, for emergency conditions and also illuminates the brake lights to warn of an impending stop.

Most electric brake controllers provide a modulation function that varies the current to the electric brakes with the pressure on the brake pedal or amount of deceleration of the tow vehicle. Electronic or timing controllers do not provide proportional modulation. These controllers tend to be inexpensive but not the best choice for optimum braking. It is important that your brake controller provide approximately 2 volts to the braking system when the brake pedal is first depressed and gradually increases the voltage to 12 volts as brake pedal pressure is increased. If the controller "jumps" immediately to a high voltage output, even during a gradual stop, then the electric brakes will always be fully energized and will result in harsh brakes and potential wheel lockup.





How to Use Your Electric Brakes Properly

Your trailer brakes are designed to work in synchronization with your tow vehicle brakes. Never use your tow vehicle or trailer brakes alone to stop the combined load.

Your brake controller must be set up according to the manufacturer's recommendations to ensure proper synchronization between the tow vehicle and the trailer. Additionally, you may have to make small adjustments occasionally to accommodate changing loads and driving conditions.

Proper synchronization of tow vehicle to trailer braking can only be accomplished by road testing. Brake lockup, grabbiness, or harshness is quite often due to the lack of synchronization between the tow vehicle and the trailer being towed, too high of a threshold voltage (over 2 volts), or under adjusted brakes.

Before any synchronization adjustments are made, your trailer brakes should be burnished-in by applying the brakes 20-30 times with approximately a 20 m.p.h. decrease in speed, e.g. 40 m.p.h. to 20 m.p.h. Allow ample time for brakes to cool between application. This allows the brake shoes and magnets to slightly "wear-in" to the drum surfaces.

Trailer Wire Size Chart

| Number of Brakes | Hitch-to-Axle Distance in Feet | Recommended Minimum Hookup Wire Size (Copper) |
|-------------------------|---------------------------------------|--|
| 2 | | 12 AWG |
| 4 | Under 30 | 12 AWG |
| 4 | 30-50 | 10 AWG |
| 6 | Under 30 | 10 AWG |
| 6 | 30-50 | 8 AWG |

Synchronizing Your Trailer Brakes

To insure safe brake performance and synchronization, read the brake controller manufacturer's instructions completely before attempting any synchronization procedure.

CAUTION

Before road testing, make sure the area is clear of vehicular and pedestrian traffic. Failure to brake safely could result in an accident and personal injury to yourself and/or others.

Make several hard stops from 20 m.p.h. on a dry paved road free of sand and gravel. If the trailer brakes lock and slide, decrease the gain setting on the controller. If they do not slide, slightly increase the gain setting. Adjust the controller just to the point of impending brake lockup and wheel skid.

Note: Not all trailer brakes are capable of wheel lockup. Loading conditions, brake type, wheel and tire size can all affect whether a brake can lock. It is not generally considered desirable to lock up the brakes and slide the tires. This can cause unwanted flat spotting of the tires and could also result in a loss of control.

If the controller is applying the trailer brakes before the tow vehicle brakes, then the controller adjustments should be made so the trailer brakes come on in synchronization with the tow vehicle brakes. For proper braking performance, it is recommended that the controller be adjusted to allow the trailer brakes to come on just slightly ahead of the tow vehicle brakes. When proper synchronization is achieved there will be no sensation of the trailer "jerking" or "pushing" the tow vehicle during braking.





General Maintenance - Electric Brakes

Brake Adjustment

Most Dexter 12¼" electric brakes have a self adjusting feature. If manual adjusting is required, use the following procedure:

Brakes should be adjusted (1) after the first 200 miles of operation when the brake shoes and drums have "seated," (2) at 3,000 mile intervals, (3) or as use and performance requires. The brakes should be adjusted in the following manner:

1. Jack up trailer and secure on adequate capacity jack stands. Follow trailer manufacturer's recommendations for lifting and supporting the unit. Make sure the wheel and drum rotates freely.

CAUTION

Do not lift or support the trailer on any part of the axle or suspension system. Never go under any trailer unless it is properly supported on jack stands which have been rated for the load. Improperly supported vehicles can fall unexpectedly and cause serious injury.

2. Remove the adjusting hole cover from the adjusting slot on the bottom of the brake backing plate.
3. With a screwdriver or standard adjusting tool, rotate the star wheel of the adjuster assembly to expand the brake shoes. Adjust the brake shoes out until the pressure of the linings against the drum makes the wheel very difficult to turn.
4. Then rotate the star wheel in the opposite direction until the wheel turns freely with a slight lining drag.
5. Replace the adjusting hole cover and lower the wheel to the ground.
6. Repeat the above procedure on all brakes. For best results, the brakes should all be set at the same clearance.

Brake Cleaning and Inspection

Your trailer brakes must be inspected and serviced immediately if a loss of performance is indicated. With normal use, servicing at one year intervals is usually adequate. With increased usage, this work should be done more frequently as required. Magnets and shoes must be changed when they become excessively worn or scored, a condition which can reduce vehicle braking.

Clean the backing plate, magnet arm, magnet, and brake shoes. Make certain that all the parts removed are replaced in the same brake and drum assembly. Inspect for any loose or worn parts, stretched or deformed springs and replace as necessary.

CAUTION

POTENTIAL ASBESTOS DUST HAZARD!

Some older brake linings may contain asbestos dust, which has been linked to serious or fatal illnesses.

Certain precautions need to be taken when servicing brakes:

- 1. Avoid creating or breathing dust.**
- 2. Avoid machining, filing or grinding the brake linings.**
- 3. Do not use compressed air or dry brushing for cleaning (dust can be removed with a damp brush).**

Brake Lubrication

Before reassembling, apply a light film of grease or anti-seize compound on the brake anchor pin, the actuating arm bushing and pin, and the areas on the backing plate that are in contact with the brake shoes and magnet lever arm. Apply a light film of grease on the actuating block mounted on the actuating arm.

CAUTION

Do not get grease or oil on the brake linings, drums or magnets.





Magnets

Your electric brakes are equipped with high quality electromagnets that are designed to provide the proper input force and friction characteristics. Your magnets should be inspected and replaced if worn unevenly or abnormally. As indicated below, a straightedge should be used to check magnet condition. For best results, the magnet should be flat.

Even if wear is normal as indicated by your straightedge, the magnets should be replaced if any part of the magnet coil has become visible through the friction material facing of the magnet. It is also recommended that the drum armature surface be refaced when replacing magnets (see section on Brake Drum Inspection). Magnets should also be replaced in pairs - both sides of an axle. Use only genuine Dexter replacement parts when replacing your magnets.

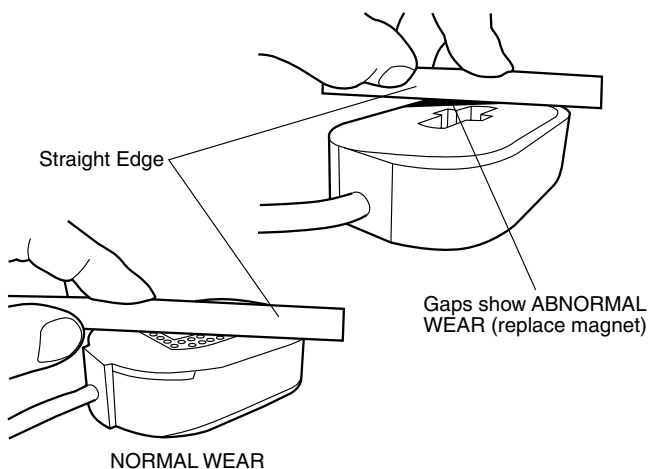

Shoes and Linings

A simple visual inspection of your brake linings will tell if they are usable. Replacement is necessary if the lining is worn to $\frac{1}{16}$ " or less. Shoes contaminated with grease or oil, or abnormally scored or gouged should also be replaced.

Hairline heat cracks are normal in bonded linings and should not be cause for concern.

When replacement is necessary, it is important to replace

both shoes on each brake and both brakes of the same axle. This will help retain the "balance" of your brakes.

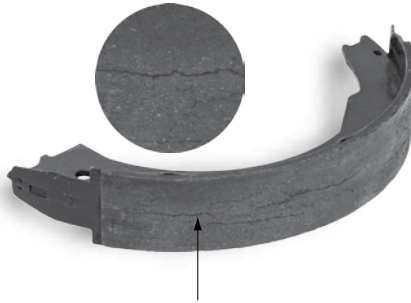

Acceptable Hairline Cracks

⚠ CAUTION

POTENTIAL ASBESTOS DUST HAZARD!

Some older brake linings may contain asbestos dust, which has been linked to serious or fatal illnesses.

Certain precautions need to be taken when servicing brakes:

- 1. Avoid creating or breathing dust.**
- 2. Avoid machining, filing or grinding the brake linings.**
- 3. Do not use compressed air or dry brushing for cleaning (dust can be removed with a damp brush).**

After replacement of brake shoes and linings, the brakes must be re-burnished to seat in the new components. This should be done by applying the brakes 20 to 30 times from an initial speed of 40 m.p.h., slowing the vehicle to 20 m.p.h. Allow ample time for brakes to cool between applications. This procedure allows the brake shoes to seat in to the drum surface.





Introduction to Troubleshooting

Proper brake function is critical to the safe operation of any vehicle. If problems are encountered with your trailer braking system, the following guide can be used to find the causes and remedies for some of the more common problems. If you are unsure or unable to resolve the problem, please contact your nearest repair facility for professional assistance.

Troubleshooting

Most electric brake malfunctions that cannot be corrected by either brake adjustments or synchronization adjustments, can generally be traced to electrical system failure. Voltmeters and ammeters are essential tools for proper troubleshooting of electric brakes.

Mechanical causes are ordinarily obvious, i.e. bent or broken parts, worn out linings or magnets, seized lever arms or shoes, scored drums, loose parts, etc. Replace defective parts with genuine Dexter replacements.

Please consult the following troubleshooting charts to determine the causes and solutions for common problems found in trailer braking systems.



CAUTION

Best braking performance is achieved with a controller setting that is just short of wheel lock up or slide. Overly aggressive braking which results in wheel lock up and sliding, can cause a dangerous loss of control and result in personal injury or death.

Troubleshooting

| SYMPTOM | CAUSES | REMEDIES |
|---------------------|--|--|
| No Brakes | Open Circuits | Find & Correct |
| | Severe Underadjustment | Adjust Brakes |
| | Faulty Controller | Test & Correct |
| | Short Circuits | Find & Correct |
| Weak Brakes | Grease or Oil on Magnets or Linings | Clean or Replace |
| | Corroded Connections | Clean & Correct Cause of Corrosion |
| | Worn Linings or Magnets | Replace |
| | Scored or Grooved Brake Drums | Machine or Replace |
| | Improper Synchronization | Correct |
| | Underadjustment | Adjust Brakes |
| | Glazed Linings | Reburnish or Replace |
| | Overloaded Trailer | Correct |
| Locking Brakes | Underadjustment | Adjust |
| | Improper Synchronization | Correct |
| | Faulty Controller | Test & Correct |
| | Loose, Bent or Broken Brake Components | Replace Components |
| | Out-of-Round Brake Drums | Machine or Replace |
| | Insufficient Wheel Load | Adjust System Resistor and Synchronize |
| Intermittent Brakes | Faulty Controller | Test & Correct |
| | Broken Wires | Repair or Replace |
| | Loose Connections | Find & Repair |
| | Faulty Ground | Find & Repair |





Troubleshooting

| SYMPTOM | CAUSES | REMEDIES |
|-------------------------|--|--------------------|
| Brakes Pull to One Side | Wrong Magnet Lead Wire Color | Correct |
| | Incorrect Adjustment | Adjust |
| | Grease or Oil on Linings or Magnets | Clean or Replace |
| | Broken Wires | Find & Repair |
| | Bad Connections | Find & Repair |
| Harsh Brakes | Underadjustment | Adjust |
| | Improper Synchronization | Correct |
| | Improper Controller | Change |
| | Faulty Controller | Test & Correct |
| Noisy Brake | Underadjustment | Adjust |
| | Lack of Lubrication | Lubricate |
| | Broken Brake Components | Replace Component |
| | Incorrect Brake Components | Correct |
| Surging Brakes | Grease or Oil on Linings or Magnet | Clean or Replace |
| | Out-of-Round or Cracked Brake Drums | Machine or Replace |
| | Faulty Controller | Test & Correct |
| Dragging Brakes | Overadjustment | Readjust |
| | Out-of-Round Brake Drums | Machine or Replace |
| | Incorrect Brake Components | Replace |
| | Loose, Bent or Broken Brake Components | Replace |
| | Faulty Breakaway Switch | Repair or Replace |
| | Loose Wheel Bearing Adjustment | Adjust |
| | Bent Spindle | Replace Axle |

How to Measure Voltage

System voltage is measured at the magnets by connecting the voltmeter to the two magnet lead wires at any brake. This may be accomplished by using a pin probe inserted through the insulation of the wires. The engine of the towing vehicle should be running when checking the voltage so that a low battery will not affect the readings.

Voltage in the system should begin at 0 volts and, as the controller bar is slowly actuated, should gradually increase to about 12 volts. If the controller does not produce this voltage control, consult your controller manual.

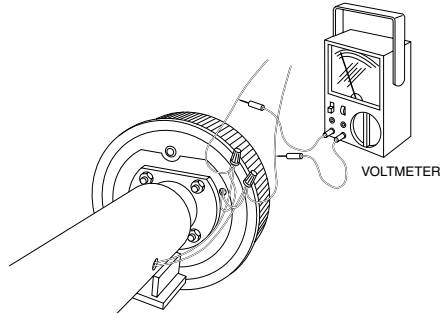

The threshold voltage of a controller is the voltage applied to the brakes when the controller first turns on. Lower threshold voltage will provide for smoother braking. If the threshold voltage is too high, the brakes may feel grabby and harsh.

How to Measure Amperage

System amperage is the current flowing in the system when all the magnets are energized. The amperage will vary in proportion to the voltage. The engine of the tow vehicle should be running with the trailer connected when checking the trailer braking system.

One place to measure system amperage is at the BLUE wire of the controller, which is the output to the brakes. The BLUE wire must be disconnected and the ammeter put in series into the line. System amperage draw should be as noted in the following table. Make sure your ammeter has sufficient capacity and note polarity to prevent damaging your ammeter. With new ammeters that have inductive pickup clamps, it is not necessary to cut the blue wire.





Magnet Amperes Chart

| Brake Size | Amps/ Magnet | Two Brakes | Four Brakes | Six Brakes |
|------------|-----------------|---------------|----------------|---------------|
| 12¼" x 3⅜" | 3.0 | 6.0 | 12.0 | 18.0 |
| 12¼" x 4" | 3.0 | 6.0 | 12.0 | 18.0 |
| 12¼" x 5" | 3.0 | 6.0 | 12.0 | 18.0 |

If a resistor is used in the brake system, it must be set at zero or bypassed completely to obtain the maximum amperage reading. Individual amperage draw can be measured by inserting the ammeter in the line at the magnet you want to check.

Disconnect one of the magnet lead wire connectors and attach the ammeter between the two wires. Make sure that the wires are properly reconnected and sealed after testing is completed.

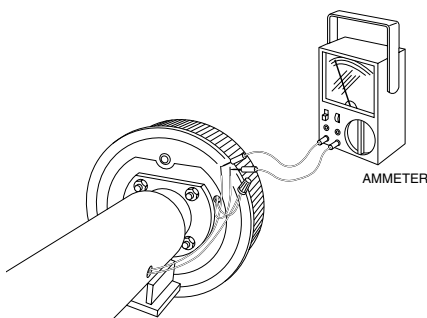

The most common electrical problem is low or no voltage and amperage at the brakes. Common causes of this condition are:

1. Poor electrical connections
2. Open circuits
3. Insufficient wire size
4. Broken wires
5. Blown fuses (fusing of brakes is not recommended)
6. Improperly functioning controllers or resistors

Another common electrical problem is shorted or partially shorted circuits (indicated by abnormally high system amperage). Possible causes are:

1. Shorted magnet coils
2. Defective controllers
3. Bare wires contacting a grounded object

Finding the cause of a short circuit in the system is done by isolating one section at a time. If the high amperage reading drops to zero by unplugging the trailer, then the short is in the trailer. If the amperage reading remains high with all the brake magnets disconnected, the short is in the trailer wiring.

All electrical troubleshooting procedures should start at the controller. Most complaints regarding brake harshness or malfunction are traceable to improperly adjusted or non-functioning controllers. See your controller manufacturer's data for proper adjustment and testing procedures. For best results, all the connection points in the brake wiring should be sealed to prevent corrosion. Loose or corroded connectors will cause an increase in resistance which reduces the voltage available for the brake magnets.





Hydraulic Brakes

The hydraulic brakes on your trailer are much like those on your automobile or light truck. The hydraulic fluid from a master cylinder or actuation system is used to actuate the wheel cylinder, which in turn applies force against the brake shoes and drum. The main difference between automotive hydraulic brakes and hydraulic trailer brakes is the trailers' actuation system. These systems respond to the braking signal from the tow vehicle and supply the required brake fluid volume and pressure to the trailer brakes.

CAUTION

The maximum operating pressure for Dexter 12 $\frac{1}{4}$ " hydraulic brakes is 1,000 PSI.



Hydraulic Drum Brake Operation

Duo-Servo

The duo-servo brake uses a dual piston wheel cylinder to apply the brakes. This type of brake is typically used in an electric/hydraulic, vacuum/hydraulic, or air/hydraulic system. A description of operation of this brake is as follows:

When the brakes are applied, the double-acting wheel cylinder

moves the primary and secondary shoes towards the drum. The frictional force between the brake drum and lining attempts to turn the primary shoe into the secondary shoe.

The secondary shoe is forced onto the anchor pin and from this point, the secondary and primary shoes attempt

to “wrap around”. In essence, the brake has utilized frictional force to help the applying force on both shoes.

If the brakes are applied while the vehicle is backing, the shoes rotate in the direction of the drum rotation. This causes the secondary shoe to leave the anchor and causes the primary shoe to move against the anchor. Action of the brake is the same in reverse as forward.

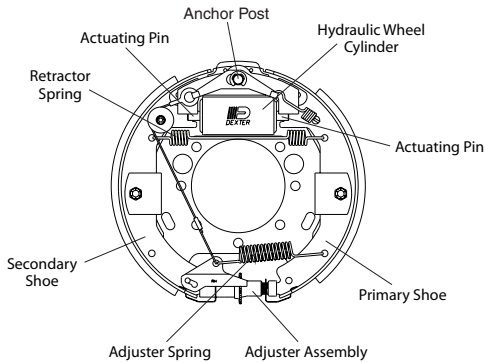



Uni-Servo

This type of hydraulic brake utilizes a single acting cylinder. Upon actuation, the primary shoe is pressed against the brake drum, which causes the shoe to move in the direction of rotation. This movement in turn actuates the secondary shoe through the adjuster link assembly. Braking in reverse is significantly less effective than in the forward direction. Uni-servo brakes are normally used with surge type actuators.

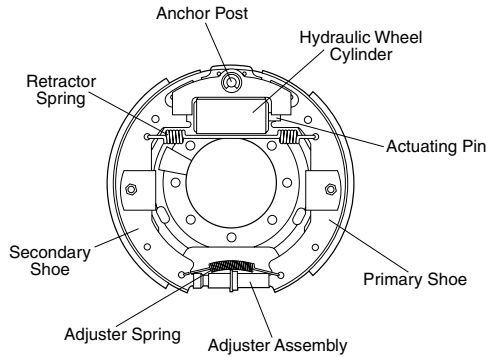

Self Adjusting Mechanism for 12¼" Hydraulic Brakes

Forward self-adjust hydraulic brakes were introduced in March, 1997. This feature adjusts the brakes on both forward and reverse stops. Brake adjustment occurs only when lining wear results in enough gap between the shoes and the drum surface. This added clearance will allow the adjuster mechanism to rotate the screw assembly at the bottom of the brake. That action expands the distance between the shoes and thus closes the gap to the drum surface.

Hydraulic Parking Brake Option

The parking feature on Dexter hydraulic brakes is cable operated. The cable end is attached to the internal parking brake lever to actuate the brake. On Dexter 12¼" brakes manufactured before February 2002, the parking cable body mounts to a support plate which is attached to the brake mounting flange. The cable end is routed through the dust shield and the brake spider to attach to the internal parking brake lever. For 12¼" brakes produced after February 2002, a short cable is installed directly into the backing plate to provide a convenient means for the trailer manufacturer to attach an appropriate operating system.

The internal parking brake lever of Dexter 12¼" brakes transfers the applied cable force through a cam mechanism. The cam mechanism generates a spreading force between the primary and secondary shoes. The shoes move toward the drum until contact is made. Friction generated between the drum and lining contact surface results in parking brake capability.





Hydraulic Disc Brakes

Dexter Axle manufactures two types of disc brakes, the floating caliper and the fixed caliper brake. With both styles, the disc brake uses friction pads astride a ventilated rotor which is attached to the wheel hub. When the brake is actuated, the pads are pressed against the sides of the rotor causing drag to slow the rotating disc. This action converts the kinetic energy (motion) into heat. The heat is dissipated rapidly by the ventilated disc.

The floating caliper brake uses piston(s) situated on one side of the brake rotor. Hydraulic fluid pressure pushes against the piston(s) to apply the inboard brake pad. As the inboard pad exerts force against the rotating rotor surface, the caliper moves laterally towards the trailer frame and in turn applies an equivalent force to the outboard brake pad against the rotor surface. As the lining material wears, the caliper will automatically maintain the proper lining to rotor clearance. The floating caliper design is used on Dexter 10,000 and 12,000 lb. axle models.

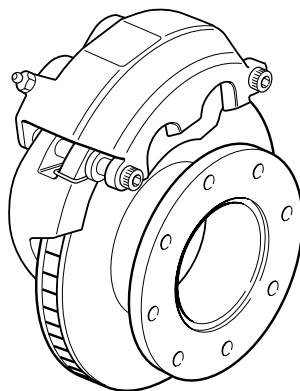

Disc brake effectiveness is the same going either in a forward or reverse direction. All Dexter disc brakes should be actuated with a braking system that is capable of providing a maximum hydraulic pressure of 1,600 psi.

Electric/Hydraulic Actuation Systems

To effectively operate your hydraulic trailer brakes, we recommend the Dexter E/H electro/hydraulic actuator, controlled by the Predator DX2™ electronic brake controller. These high performance hydraulic power modules will supply pressurized brake fluid to your trailer brakes in proportion to the amount of braking effort called for by the towing vehicles' deceleration rate.

CAUTION

It is the responsibility of the end user to ensure that their in-cab electronic controller is compatible with the Dexter E/H actuator. Dexter Axle attempts to provide compatibility with most controllers available, but is unable to anticipate design changes that might be introduced by the various controller manufacturers.

The E/H 1000 will supply 1,000 psi for your drum brakes and the E/H 1600 will generate 1,600 psi for maximum output for your Dexter disc brakes. The sealed, weather tight housing contains the electronics necessary to control the high pressure piston pump and proportioning valve for smooth, efficient braking.

Vacuum/Hydraulic

The basic actuation system consists of a vacuum booster, synchronizing valve, check valve and a plumbing kit which includes all lines and fittings. A vacuum supply from the engine manifold is routed to the front of the booster and the top chamber of the synchronizing valve through flexible hoses. The rear of the booster and the lower chamber of the synchronizing valve are connected by a separate line. The vacuum from the engine must pass through a normally closed check valve. The check valve keeps gas vapor out of the system and insures that the highest vacuum available will be kept in the system. With the engine running and with no brake pedal pressure, a vacuum exists throughout the system. The synchronizing valve is connected to the master cylinder hydraulic supply. When the brake pedal is applied, the hydraulic pressure in the synchronizing valve forces a poppet to open which allows atmospheric air to enter the bottom





chamber of the valve. Since this part of the valve is connected to the rear of the vacuum booster, the vacuum on this side of the booster chamber is lost. The vacuum on the front side of the booster chamber is maintained and this atmospheric/vacuum pressure differential causes a piston to move in the booster's slave cylinder. This piston applies the hydraulic pressure to the brakes through the connecting hydraulic line. When the pedal is released, the poppet in the synchronizing valve is closed and by internal passages, the air in the rear of the booster chamber is removed. This restores a vacuum which is equal to the vacuum in the front part of the booster chamber. The pressure balance allows the slave cylinder piston to be pulled back to its original position and the hydraulic pressure to the brakes is released.

Air/Hydraulic

Air/hydraulic braking systems are commonly used when the tow vehicle has a diesel engine which does not develop manifold vacuum. The air/hydraulic tow vehicle has an air compressor mounted on the engine to supply compressed air for the braking system and other needs required by the tow vehicle trailer combination. This air is routed to a booster chamber attached to the trailer master cylinder. The air pressure multiplies hydraulic output pressure which then sends fluid to the wheel cylinders. The air over hydraulic systems are often controlled by a series of control valves and servos to insure proper braking under all conditions.

Introduction to Troubleshooting

Proper brake function is critical to the safe operation of any vehicle. A properly installed vacuum/hydraulic, electric/hydraulic, or air/hydraulic system should not require any special attention with the exception of routine maintenance as defined by the manufacturer. If problems occur, the entire tow vehicle/trailer braking system should be analyzed by a qualified mechanic.

Typical problems in a hydraulic braking system are:

- Air or vacuum leaks
- Hydraulic system leaks
- Air in brake lines
- Water or other impurity in brake fluid
- Rusted or corroded master or wheel cylinders
- Actuation system malfunction

Please consult the following troubleshooting charts to determine the causes and solutions for common problems found in trailer braking systems.





Troubleshooting

| SYMPTOM | CAUSES | REMEDIES |
|-------------------|--|--|
| Noisy Brakes | Underadjustment | Adjust |
| | Lack of Lubrication | Lubricate |
| | Broken Brake Components | Replace Components |
| | Incorrect Brake Components | Correct |
| Locking Brakes | Loose, Bent or Broken Brake Components | Replace Components |
| | Underadjustment | Adjust |
| | Out-of-Round Drums | Machine or Replace |
| Pulls to One Side | Incorrect Tire Pressure | Inflate Evenly on Both Sides to Req. Pressures |
| | Unmatched Tires on Same Axle | Match Tires on Axle |
| | Restricted Brake Lines or Hoses | Repair or Replace |
| | Malfunctioning Cylinder Assembly | Check for Stuck or Sluggish Pistons |
| | Defective or Damaged Shoe and Lining | Install New Shoe and Lining-Complete Axle |
| | One Side Out-of-Adjustment | Adjust |
| Dragging | Improper Fluid | Replace Rubber Parts Fill with DOT4 Fluid |
| | Blocked Master Cylinder | Open with Compressed Air or Replace Cylinder |
| | Parking Brake Cable Frozen | Free Cable and Lubricate |
| | Improper Lining Thickness or Location | Install New Shoes and Linings |

Troubleshooting

| SYMPTOM | CAUSES | REMEDIES |
|----------------|--|--|
| No Brakes | Broken or Kinked Brake Line | Repair or Replace |
| | Severe Underadjustment | Adjust Brakes |
| | Malfunctioning Actuation System | Troubleshoot System |
| Weak Brakes | Brake Adjustment Not Correct | Manual-Adjust Brakes Automatic-Make Several Reverse Stops |
| | Excessively Worn Brake Linings | Replace Shoe and Lining |
| | Incorrect Lining | Install Correct Shoe and Lining |
| | Grease or Fluid Soaked Lining | Repair Grease Seal or Wheel Cylinder. Install New Shoe and Lining. |
| | Frozen Master Cylinder or Wheel Cylinder Pistons | Recondition or Replace All Cylinders, Brake Fluid |
| | Glazed Lining | Reburnish or Replace |
| | Excessive Drum Wear | Replace |
| | Trapped Air in Lines | Bleed System |
| | Overloaded Trailer | Correct |
| | Malfunctioning Actuating System | Troubleshoot System |
| Harsh Brakes | Brake Adjustment Not Correct | Manual-Adjust Brakes Automatic-Make Several Reverse Stops |
| | Grease or Fluid on Linings | Replace Shoes and Linings |
| Surging Brakes | Grease or Oil on Linings | Clean or Replace |
| | Out of Round Drums or Cracked Drums | Machine or Replace |





Electric/Hydraulic Troubleshooting Guide

Electrical Schematic

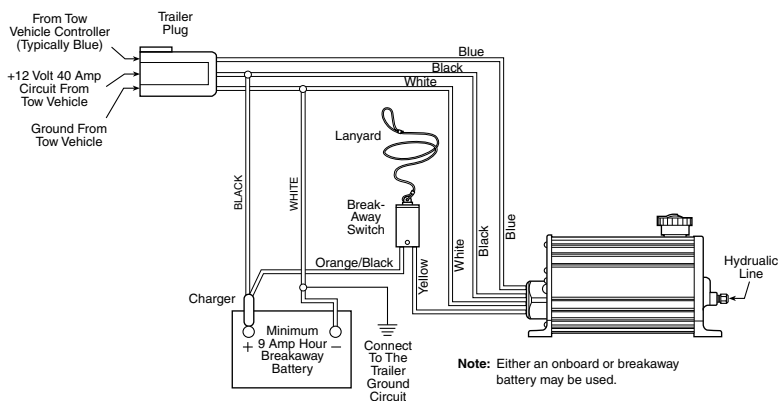

Brakes are slow to respond

1. Re-bleed the trailer brakes and actuator.
2. If the trailer is equipped with drum brakes, readjust the drum brakes to the brake manufacturer's recommended running clearance.
3. Slow response can be caused by trailer wiring that is too small.
4. For trailers where the E/H unit is located less than 10 feet from the tow vehicle, 12 gage wire is recommended for the black and white wires between the tow vehicle and the E/H unit. All other wires should be a minimum of 16 gauge.
5. For trailers where the E/H unit is located more than 10 feet from the tow vehicle, 10 gage wire is recommended for the black and white wires between the tow vehicle and the E/H unit. All other wires should be a minimum of 16 gauge.
6. Slow response can be caused by improper adjustment of the brake controller. On inertia-based electronic brake controls, adjust the pendulum (inertia sensor) to a more aggressive setting and/or increase the gain setting.

Unit will not run when the ignition is on and the brake pedal is depressed

1. Verify that the trailer and tow vehicle are wired as detailed on the electrical schematic.
2. With the ignition switch on and the brakes not applied, you should have 12-13 volts between the black and white wires on the E/H unit.
3. Clean and replace the ground between the trailer and the E/H unit.
4. Test operation of the unit using the breakaway test procedure.

Breakaway test procedure - do not leave the breakaway switch pulled for more than two minutes during any of the steps outlined below

1. Pull the breakaway switch on the trailer.
2. If the unit runs and builds pressure, that indicates the actuator is functioning properly. The problem most likely is a defective electronic brake controller in the tow vehicle or defective wiring between the tow vehicle and the E/H unit.
3. If the unit runs but will not build pressure, the problem most likely is a defective solenoid valve in the E/H unit and the actuator should be returned for repair.
4. If the unit still does not run after the breakaway battery is fully charged, verify that the voltage between the white wire and yellow wire is at least 12 volts.
5. If the voltage is less than 12 volts, either the breakaway switch or the breakaway wiring is defective.
6. If the voltage is greater than 12 volts, the E/H unit should be returned for repair.

Trailer brakes too aggressive

1. Reduce the gain setting on the in-cab electronic brake controller.





General Maintenance - Hydraulic Brakes

Drum Brake Adjustment

Most Dexter 12¼" hydraulic brakes have a self adjusting feature. If manual adjusting is required, use the following procedure:

Brakes should be adjusted (1) after the first 200 miles of operation when the brake shoes and drums have "seated," (2) at 3,000 mile intervals, (3) or as use and performance requires. The brakes should be adjusted in the following manner:

1. Jack up trailer and secure on adequate capacity jack stands. Follow trailer manufacturer's recommendations for lifting and supporting the unit. Make sure the wheel and drum rotates freely.

CAUTION

Do not lift or support the trailer on any part of the axle or suspension system. Never go under any trailer unless it is properly supported on jack stands which have been rated for the load. Improperly supported vehicles can fall unexpectedly and cause serious injury or death.

2. Remove the adjusting hole cover from the adjusting slot on the bottom of the brake backing plate.
3. With a screwdriver or standard adjusting tool, rotate the star wheel of the adjuster assembly to expand the brake shoes. Adjust the brake shoes out until the pressure of the linings against the drum makes the wheel very difficult to turn.
4. Then rotate the star wheel in the opposite direction until the wheel turns freely with a slight lining drag.
5. Replace the adjusting hole cover and lower the wheel to the ground.
6. Repeat the above procedure on all brakes. For best results, the brakes should all be set at the same clearance.

Most of the brake components are very similar to those used in electric brakes, and maintenance is comparable for the hub and drum, shoes and linings, and bearings. Specific maintenance activities are as follows:

Wheel Cylinders

Inspect for leaks and smooth operation. Clean with brake cleaner and flush with fresh brake fluid. Hone or replace as necessary.

Brake Lines

Check for cracks, kinks, or blockage. Flush with fresh brake fluid. Bleed system to remove all air. Use DOT3 or DOT4 brake fluid, and replace as necessary.

Shoes and Linings

A simple visual inspection of your brake linings will tell if they are usable. Replacement is necessary if the lining is worn (to within 1/16" or less), contaminated with grease or oil, or abnormally scored or gouged. Hairline heat cracks are normal in bonded linings and should not be cause for concern. When replacement is necessary, it is important to replace both shoes on each brake and both brakes of the same axle. This will help retain the "balance" of your brakes.

CAUTION

POTENTIAL ASBESTOS DUST HAZARD!

Some older brake linings may contain asbestos dust, which has been linked to serious or fatal illnesses.

Certain precautions need to be taken when servicing brakes:

- 1. Avoid creating or breathing dust.**
- 2. Avoid machining, filing or grinding the brake linings.**
- 3. Do not use compressed air or dry brushing for cleaning (dust can be removed with a damp brush).**





After replacement of brake shoes and linings, the brakes must be re-burnished to seat in the new components. This should be done by applying the brakes 20 to 30 times from an initial speed of 40 m.p.h., slowing the vehicle to 20 m.p.h. Allow ample time for brakes to cool between applications. This procedure allows the brake shoes to seat in to the drum surface.

Hardware

Check all hardware. Check shoe return spring, hold down springs, and adjuster springs for stretch or wear. Replace as required. Service kits are available.

Instructions for 10-12K Hydraulic Disc Brakes

Notice to Buyer

It is recommended that all brakes be replaced at the same time to insure balanced braking performance.

Preparation

1. Jack up trailer and secure on adequate capacity jack stands. Follow trailer manufacturers recommendations for lifting and supporting the unit.



CAUTION

Do not lift or support the trailer on any part of the axle or suspension system. Never go under any trailer unless it is properly supported on jack stands which have been rated for the load. Improperly supported vehicles can fall unexpectedly and cause serious injury or death.

2. Remove the wheel from the hub, leaving the brake exposed.

Removal of Old Brake Caliper

1. With tire-wheel assembly(s) removed from hub and zero pressure in hydraulic system, remove hex nuts from slider bolts and withdraw bolts from brake assembly. Note orientation of anti-rattle springs. Lift calipers from assembly and secure to prevent damage to brake hose. Do not allow caliper to hang from the hose. Remove anti-rattle springs and brake pad.

Inspection

1. Slider bolts must be straight and free of rust pits, missing chrome, or cracks in the chrome plating. Replace if necessary. Anchor yoke bores must be free of corrosion and excessive wear. “O” rings must be free from nicks and cuts. Replace as necessary. Caliper assembly must be free of fluid leaks and torn or deteriorated dust boots and “O” rings. Repair as required.
2. Rotor-inspect for grooves, flaking, cracks, heat checking, excessive thickness variation, insufficient overall rotor thickness and overall width (measurement from inboard rotor face to rotor mounting surface). Machine or replace as necessary.
3. Rotor Specifications:

| | |
|---------------------|------------------------------------|
| Rotor Thickness | 1.185 New, 1.12 Min. Service Limit |
| Rotor Overall Width | 3.655 New, 3.59 Service Limit |
| Lateral Runout | .003 T.I.R., .010 T.I.R. Maximum |
| Thickness Variation | .0008 |

Hub and Rotor Removal and Installation

1. With hubcap removed and oil drained, straighten locking tabs on tang washer and remove outer locknut, tang washer, inner locknut, bearing washer, and outer bearing. Remove hub and rotor assembly.

Note: A puller may be required due to unitized seal press fit on spindle. Remove inner bearing and seal. Service bearings as necessary.

2. Prior to reassembly, insure that the hub bearing housing is clean. Reinstall inner bearing. Coat the O.D. of a new seal with a bore sealant (Permatex or equivalent) prior to installation.
3. Mount hub and rotor assembly on spindle and install outer bearing, bearing washer, and inner bearing nut.
4. Tighten inner nut to **100 Ft. Lbs.** while turning hub to seat bearings.





5. Loosen nut to remove pre-load torque. Hand tighten nut, then back off $\frac{1}{8}$ turn minimum, $\frac{1}{4}$ turn maximum.
6. Install tab washer and outer locknut. Torque locknut to **100-175 Ft. Lbs.** Insure that the inner nut does not rotate. Bend 2 tabs over flat on outer locknut to secure.
7. Install hub cap and add oil to hub. Capacity is 2.5 oz. of SAE 90W gear oil.

Installation

1. Installation is reverse of disassembly. Use appropriate tools and methods to retract caliper pistons sufficiently to reinstall caliper over the new pads. Caliper and anchor yoke “O” rings should be lubricated with a light film of high temperature brake lubricant prior to slider bolt installations. Slider bolts should be installed from the outboard side of the caliper. Insure the anti-rattle springs are located properly.
2. Use extreme care when installing the slider bolts to prevent damage to the “O” rings. Installation tool #071-182-00 threaded onto the slider bolts is recommended.
3. **DO NOT FORCE OR HAMMER BOLTS IN.** Secure slider bolts with new locknut. Actuate brakes numerous times to remove excess pad clearance prior to operation of vehicle.

Torque Specifications:

| | |
|--|------------------|
| Slider Bolts Locknuts | 15-25 Ft. Lbs. |
| Anchor Yoke Mounting Nuts | 45-55 Ft. Lbs. |
| Bleeder Screw | 9-12 Ft. Lbs. |
| Rotor Mounting Nuts | 85-95 Ft. Lbs. |
| Outer Spindle Nuts | 100-175 Ft. Lbs. |
| Hub Cap | 20-30 Ft. Lbs. |
| Wheel Mounting Nuts (with clamp ring) | 200 Ft. Lbs. |

Hydraulic Disc Brake Parts

| Item | Description | Qty/ Brake | 10K, 12K |
|--|---|---------------|-------------|
| 1 | Anchor Yoke Assembly (includes 6 of item #6) | 1 | 090-002-02 |
| 2 | Caliper Assembly (includes items #6, 3, 9, 10) | 1 | 089-002-002 |
| 3 | Caliper Piston | 2 | 054-066-00 |
| 12 | Shoulder Screw $\frac{5}{8}$ x 5 | 2 | 007-186-00 |
| 13 | Hex Screw $\frac{7}{16}$ -20 x 1.75 | 7 | 007-116-00 |
| 14 | Flange Nut | 8 | 006-046-00 |
| 15 | Hex Nut $\frac{7}{16}$ -20 | 7 | 006-017-00 |
| 16 | Rotor Mounting Stud | 8 | 025-014-00 |
| 17 | ABS Sensor (straight) | 1 | 097-004-00 |
| 19 | ABS Sensor Retaining Clip | 1 | 097-002-00 |
| 20 | ABS Tone Ring | 1 | 024-203-00 |
| Caliper Repair Kit contains: | | 1 | K71-181-00 |
| 6 | "O" Ring | 4 | 010-062-00 |
| 7 | Bleeder Screw | 1 | 054-069-00 |
| 9 | Caliper Seal | 2 | 054-067-00 |
| 10 | Dust Boot | 2 | 054-068-00 |
| Disc Brake Replacement Pad Kit contains: | | 1 | K71-180-00 |
| 4 | Brake Pad | 4 | 091-003-00 |
| 5 | Anti-Rattle Spring | 4 | 046-105-00 |
| 6 | "O" Ring | 20 | 010-062-00 |
| 8 | Hex Locknut | 4 | 006-125-00 |
| 11 | Installation Tool | 1 | 071-182-00 |

Recommend hose with banjo fitting.
 $\frac{7}{16}$ -20 threaded hole for fitting.

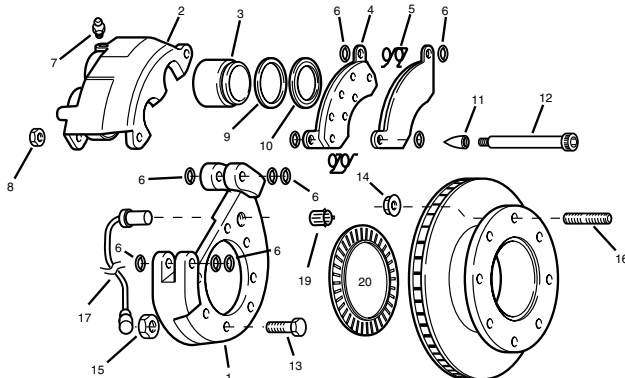



S-Cam Air Brakes

Operation

Trailer air brakes are operated by the tractor air supply through a series of relay and check valves. When braking is desired, the air is supplied to the axle air chamber which applies a force that is multiplied by the slack adjuster lever arm length. This force is transmitted rotationally through the camshaft which, through the geometry of the S-head, spreads the brake shoes to contact the brake drum surface. The air brake systems are an effective, very durable braking system for use in high mileage or extreme operating conditions. They can be outfitted with ABS (anti-lock brake systems), automatic slack adjusters and spring brakes to comply with Federal Motor Vehicle Safety Standard Part 571.121.

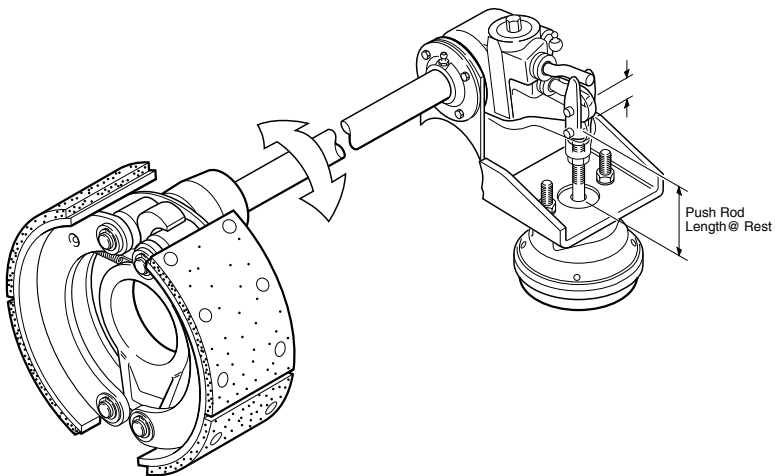

Air Brake Components

Air Chambers

The air chambers convert the compressed air into a mechanical force on the slack adjuster. The force on the slack adjuster operates on the end of the lever and converts the chamber output force to a torque on the S-cam. Federal and state regulations state the maximum pushrod stroke length as an indication of brake adjustment. This stroke is shown by the maximum stroke indicator located on the air chamber pushrod. Maximum allowable stroke is achieved when the indicator is fully extended from the air chamber housing.

Note: Due to manufacturing tolerances, some brakes may not meet the maximum stroke length in the “green” state and may require several burnish stops to allow the brake shoes to conform to the drum diameter.

Spring Brake

For parking and emergency braking purposes, a spring brake chamber can be used in conjunction with the standard air chamber. The spring brake contains an additional air diaphragm and a very strong spring. When air is applied to the spring brake, the spring is held in the off position by the air diaphragm. When the air is exhausted, the spring provides the braking force to the air chamber pushrod, thus actuating the brakes.



CAUTION

Do not disassemble the spring brake! It contains a compressed spring that may cause injury if removed. The spring brake must be caged before servicing and should only be performed by qualified personnel.





Slack Adjusters

The air brake slack adjusters perform two functions: (1) The slack adjuster acts as a lever arm to convert the linear pushrod force to rotational camshaft torque. The length of the slack adjuster determines the amount of torque multiplication provided from the pushrod. (2) Allows a simple external adjustment of the lining to drum clearance to compensate for shoe lining wear.

There are two types of slack adjusters, manual and automatic:

Manual slack adjusters

The manual slack adjusters require manual adjustment to compensate for the brake lining wear and the associated drum to lining gap that results. Adjustment is usually performed by rotating the hex adjusting nut on the slack adjuster body to set a lining to drum clearance of about .020-.030". See instructions for manual slack adjustment procedure.

Automatic slack adjuster

The automatic slack adjuster (ASA) maintains an optimum clearance between the brake lining and the drum by automatically adjusting on the return stroke during brake application. Various brands of ASA's may work differently. The initial adjustment and set-up of the ASA's is critical to proper function of the air brake. See instructions for slack adjuster procedure.

Note: Automatic slack adjusters are required on some commercial trailers over 26,000 lbs., manufactured after 10/20/94 per FMVSS Part 571.121. **DO NOT REPLACE AUTOSLACKS WITH MANUAL SLACK ADJUSTERS ON THESE TRAILERS.**

S-Cams

The S-cams rotate from the torque applied by the slack adjusters, resulting in spreading the brake shoes which applies the braking force to the drum. The S-cams are supported by two nylon, grease lubricated bushings. Due to the high forces exerted on the cam bushings, periodic inspection, lubrication and maintenance is required to achieve proper braking performance.

Brake Shoes

The air brake shoes are the final link in the braking system. The brake shoes are supported by pins inserted into the brake spider, and rollers that contact the S-cam surface. The shoes have a replaceable lining riveted to them. The linings have two different blocks, designated Cam and Anchor side. The brake shoes on your Dexter axle are specifically designed for that axle. Only Dexter authorized parts should be used for replacement since there are small dimensional differences between air brake parts suppliers that can significantly affect the function of the brake.



CAUTION

Improperly fitted brake parts can cause brakes to malfunction and cause loss of braking and/or wheel lockup. Loss of braking can cause an accident resulting in injuries or death.

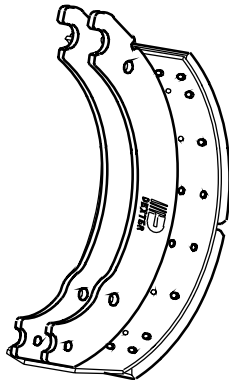



General Maintenance/Adjustment

Brake Component Lubrication

Camshaft bushings

Lubricate with approved grease through the grease fittings at the spider and camshaft support bracket locations. Apply just enough grease so grease is visible flowing past camshaft bushing seals. During this process it is advisable to grab the camshaft and shake the camshaft to see if there is excessive clearance in the camshaft bushings due to wear.

Camshaft roller journals and brake anchor pins

These components are to be lubricated with a high temperature anti-seize grease upon disassembly, maintenance and reassembly.

Manual and automatic slack adjusters

Lubricate with Lithium base NLGI Grade 1 anti-wear grease with rust and oxidizer additives applied at intervals of 3 to 6 months or 50,000 miles or per slack adjuster manufacturer's recommendations.

For Manual Slack Adjusters

Lubricate with NLGI Grade 2

For Automatic Slack Adjusters

Lubricate with ASA manufacturers recommended lubricant

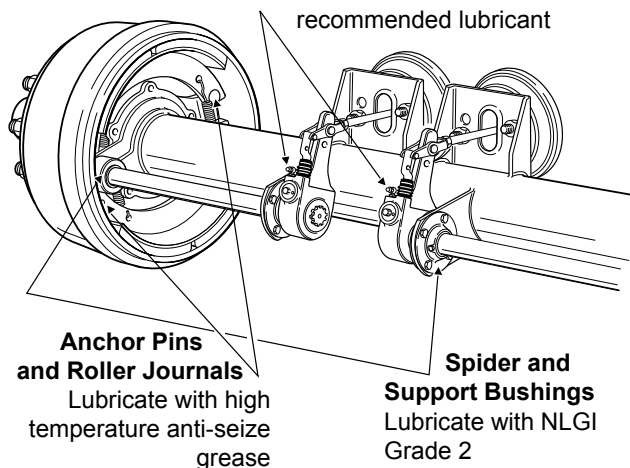

12¹/₄" Quick Change Brakes - PQ

Recommended Disassembly

1. Block and secure trailer on adequate capacity jack stands. Follow trailer manufacturers recommendations for lifting and supporting the unit. Check that the wheel and drum rotate freely.
2. Release brake and back off slack adjuster.
3. Remove wheel equipment.
4. Lift top shoe upward to disengage the shoe webs from the anchor pin. Remove anchor pin.
5. Repeat procedure 4 for the bottom shoe.
6. Remove brake keeper springs.
7. Unwrap bottom shoe by pivoting the shoe on the camshaft head and twisting the shoe 90° under the spindle. Remove shoe assemblies from spider.
8. Remove slack adjuster lock ring, disconnect slack clevis, and then remove slack adjuster.
9. Remove camshaft lock ring, spacer washer(s) and camshaft.
10. Completely inspect all brake components, servicing as necessary.

Recommended Reassembly

1. Install new camshaft bushing. Ream bushing to 1.505/1.515 if required. Install camshaft seals into the spider.

Note: When installing camshaft seals, the seal on the slack adjuster side is installed with seal facing into spider. This allows grease to purge outside the brake assembly when greasing the camshaft bushing. It also aids to avoid damage of the seal lip when camshaft is installed.

2. Install new cam roller assemblies onto the brake shoes.

Note: The head of roller pin should face the camshaft "D" washer once shoes are installed on spider.





3. Install “D” shaped camshaft washer onto the camshaft.
4. Install the camshaft into the spider. Install 005-075-00 washer and lock ring retainer on the camshaft before sliding the camshaft through the camshaft support bracket.
5. Install the slack adjuster and 005-134-00 washer and 069-078-00 lock ring retainer for 28 spline camshafts or 005-075-00 washer and 069-020-00 lock ring retainer for 10 spline camshafts.
6. Lubricate cam roller notches with anti-seize lubricant prior to installing cam roller assemblies onto the brake shoes. Bend roller retainer loop down so that retainer will be at same level as the shoe table and will not interfere with the brake drum during the life of the lining blocks.
7. Install “W” shaped retractor spring retainer pin into the 0.50" diameter shoe web holes near the camshaft roller end of the shoe.
8. Install retractor spring between shoes. Place top shoe onto spider as in service. Pivot bottom shoe on the camshaft head and twist the shoe 90° under the spindle, properly placing shoe on the spider as in service.
9. Install two (2) keeper springs on the anchor end of the shoes.
10. Lubricate anchor pin bores and shoe anchor pins with antiseize lubricant.
11. Repeat procedure 10 for the bottom shoe.
12. Lift top shoe upwards to clear anchor pin hole. Install anchor pin.
13. Connect slack adjuster to brake chamber pushrod.

Note: Always use new springs when servicing brakes.
Always use Dexter shoes when replacing shoes.

Air Brake Automatic Slack Adjustment

Mounting and adjustment procedure

If available, use installation template per manufacturer's directions. If template is not available, use the following procedure:

1. Install air chamber with proper push rod length.
2. Install the slack onto the camshaft.
3. Adjust the slack arm up to the point where the slack arm starts to engage into the clevis slot.
4. Take the ½" diameter pivot pin, and place it into the clevis slot. Hold in place (at this point, the pin is like a shim).
5. Continue adjusting the slack arm back against the pin.
6. When the slack arm touches the pin, the slack rotation will stop. The camshaft will start to rotate as you keep adjusting the slack with the wrench.
7. Continue adjusting with the wrench, which is now bringing the shoes into closer contact with the drum.
8. As you continue to adjust, spin the drum by hand to get a feel for the brake drag.
9. Adjust until the drum stops.
10. Adjust an additional ¼ to ½ turn of the wrench.
11. Pull slack away by hand, from the pin.
12. Remove the pin from the clevis slot.
13. Align ½" holes.
14. Insert ½" pin.
15. Make sure the drum rotates one (1) full revolution. If it did, proceed to step sixteen (16). If it did not rotate one revolution, remove the air chamber and slack. Start over at step one (1). Do not tighten the adjuster hex nut as tight as previously done.
16. Insert the ¼" pin.
17. Install and secure the cotter pins in the clevis and adjuster pins.





CAUTION

To insure brakes meet Federal performance requirements, Dexter Axle recommends that only original equipment premium grade linings be used. Failure to use proper linings can result in poor braking and cause accidents and injuries.

Air Brake Manual Slack Adjustment

1. Grease cam bracket and spider fittings.
2. Adjust the slack adjuster until the brake lining comes into contact with the brake drum.
 - A. For green brakes, there should be a slight amount of wheel drag at initial adjustment to compensate for any lining irregularities such as high spots.
 - B. For burnished or broken-in brakes, back off the slack adjuster to achieve .010" clearance between the drum and shoes.
3. Apply brakes using normal truck operating pressure (80-90 psi).

Note: A "green brake" is an unground, unburnished, brake. Normal manufacturing tolerances dictate that there is a break-in period required after which the lining will seat into the brake drum. During this break-in period, the user must be aware that additional brake adjustment will be mandatory to achieve optimum braking performance.

CAUTION

USE OF AIR PRESSURE IN EXCESS OF 130 PSI COULD RESULT IN FAILURE OF THE AIR CHAMBER OR SPRING BRAKE CHAMBER.

4. Check the amount of push rod travel at the clevis pin. The stroke should be as follows:

| Chamber Type | Maximum Stroke |
|--------------|----------------|
| 9 | 1½" |
| 12 | 1½" |
| 16 | 1½" |
| 20 | 1¾" |
| 24 | 1¾" |
| 30 | 2" |

5. With air pressure applied to brakes, check for lining to drum contact. The contact should approach 100%. Use a .010" feeler gage if in doubt. It should not fit between the lining and drum during brake application.
6. Release air pressure from the brakes and confirm that all brakes release to the normal relaxed position.
- A. When properly adjusted, the angle between the push rod and the slack adjuster should be approximately 90° +/- 5° when the brakes are applied.
- B. Proper maximum stroke should be achieved after adjusting the autoslack. Reference the push rod stroke length chart.





Introduction to Troubleshooting

Proper brake function is critical to the safe operation of any vehicle. A properly installed air brake system should not require any special attention with the exception of routine maintenance as defined by the manufacturer. If problems occur, the entire tow vehicle/trailer braking system should be analyzed by a qualified mechanic.

To assure safe operation and maximum durability of parts such as brake linings and tires, it is necessary to position and install the axle properly. It is recommended that the axle assembly be installed so that camshafts rotate in the same direction as the wheels. Installation in which the camshaft rotation is opposite that of wheel rotation could cause noisy brakes, chatter, and wheel “hop”. With this thought in mind, the axle should be ordered with placement of air chamber and slack adjuster assemblies that will insure the correct directional rotation of the camshafts when the axle is installed.

It is the responsibility of the axle installer to adjust the brakes properly. The recommended adjustment procedure is covered in the section pertaining to brakes.

Please consult the following troubleshooting charts to determine the causes and solutions for common problems found in trailer braking systems.

Troubleshooting

| SYMPTOM | CAUSES | REMEDIES |
|-----------------------|---|--|
| No Brakes | S-Cam Flipped | Replace Linings and Drum If Needed |
| | Air System Malfunction | Troubleshoot per System Mfgr's Directions |
| | Brakes Out of Adjustment | Adjust Brakes |
| | Air Lines Kinked or Broken | Replace |
| | Slack Adjuster Broken | Repair or Replace |
| | Air Chamber Malfunction | Replace |
| Weak Brakes | Brakes Out of Adjustment | Adjust |
| | Excessive Drum Wear | Replace Drums |
| | Excessive Lining Wear | Replace Linings |
| | Oil Soaked Linings | Replace Linings |
| | Overloaded Trailers | Use Proper Load |
| | Air System Malfunction | Troubleshoot per System Mfgr's Directions |
| | Wrong Size Air Chamber | Use Correct Size Air Chamber for Application |
| | Worn Anchor Pin Bushings or Camshaft Bushings | Replace Bushings |
| | Harsh Brakes | Brake Adjustment Not Correct |
| Oil on Linings | | Replace Linings |
| Wrong Brake Component | | Use Only Approved Dexter Components |





Troubleshooting

| SYMPTOM | CAUSES | REMEDIES |
|--------------------|---|--|
| Brake Lock-Up | Cams Froze in Park Position | Replace Camshaft Bushings |
| | Wrong Size Air Chamber | Use Correct Size Air Chamber |
| | Incorrect Slack Adjuster Length | Use Correct Length Slack Adjuster |
| | Air System Timing Malfunction - Too Low Relay Valve - Crack Pressure - Quick Release Valve Malfunction | Troubleshoot per System Mfg's Directions |
| | S-Cam Flipped Due to Brake Lining Wear | Replace Linings, Adjust |
| | Broken Return Springs | Determine Cause of Breakage and Replace |
| Surging Brakes | Grease or Oil on Linings | Replace Linings |
| | Out of Round or Cracked Drums | Turn or Replace Drums |
| Overheating Brakes | Linings Dragging Due to Weak or Broken Return Spring | Replace Return Springs |
| | Wrong Component in Brake | Use Only Dexter Approved Components |
| | Bearing Adjustment | Re-adjust |
| | Air System Malfunction Sticky Valves, Dirt, etc. | Troubleshoot per System Mfg's Directions |
| | Improper Mounting of Air Chamber and Slack Adjuster | Mount per Recommended Procedure |
| | Camshaft or Shoes Frozen | Replace Bushing |

Hubs/Drums/Bearings

Hub Removal

Whenever the hub equipment on your axle must be removed for inspection or maintenance the following procedure should be utilized.

1. Elevate and support the trailer unit per manufacturers' instructions.

CAUTION

Do not lift or support the trailer on any part of the axle or suspension system. Never go under any trailer unless it is properly supported on jack stands which have been rated for the load. Improperly supported vehicles can fall unexpectedly and cause serious injury or death.

2. Remove the wheel(s).
3. Remove the grease or oil cap by unscrewing it counterclockwise while holding the hub stationary.
4. Bend the locking tang down from the outer spindle nut and remove spindle nut.
5. Remove the tang washer and unscrew the inner spindle nut (counterclockwise) and remove the spindle washer.
6. Remove the hub from the spindle, being careful not to allow the outer bearing cone to fall out. The inner bearing cone will be retained by the seal.

Note: A gear puller may be necessary to remove hub from spindle.

Brake Drum Inspection

There are two areas of the brake drum that are subject to wear and require periodic inspection. These areas are the drum surface where the brake shoes make contact during stopping and the armature surface where the magnet contacts (only in electric brakes).





The drum surface should be inspected for excessive wear or heavy scoring. If worn more than .020" oversized, or the drum has worn out of round by more than .015", then the drum surface should be re-machined. If scoring or other wear is greater than .090" on the diameter, the drum must be replaced. When turning the drum surface, the maximum rebores diameter for a 12¼" brake drum is 12.340".

For electric brakes only, the machined inner surface of the brake drum that contacts the brake magnet is called the armature surface. If the armature surface is scored or worn unevenly, it should be refaced to a 120 micro inch finish by removing not more than .030" of material. To insure proper contact between the armature face and the magnet face, the magnets should be replaced whenever the armature surface is refaced and the armature surface should be refaced whenever the magnets are replaced.

Note: It is important to protect the wheel bearing bores from metallic chips and contamination which result from drum turning or armature refacing operations. Make certain that the wheel bearing cavities are clean and free of contamination before reinstalling bearing and seals. The presence of these contaminants will cause premature wheel bearing failure.

Bearing Inspection

Wash all grease and oil from the bearing cone using a suitable solvent. Dry the bearing with a clean, lint-free cloth and inspect each roller completely. If any pitting, spalling, or corrosion is present, then the bearing must be replaced. The bearing cup inside the hub must be inspected.

IMPORTANT: Bearings must always be replaced in sets of a cone and a cup.

CAUTION

Be sure to wear safety glasses when removing or installing force fitted parts. Failure to comply may result in serious eye injury.

When replacing the bearing cup proceed as follows:

1. Place the hub on a flat work surface with the cup to be replaced on the bottom side.
2. Using a brass drift punch, carefully tap around the small diameter end of the cup to drive out.
3. After cleaning the hub bore area, replace the cup by tapping in with the brass drift punch. Be sure the cup is seated all the way up against the retaining shoulder in the hub.

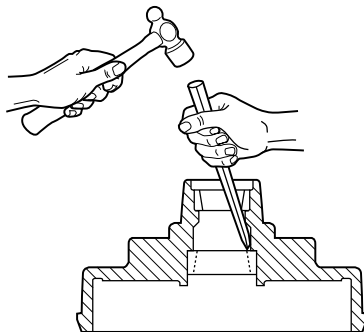

Replace only with bearings as specified in the Bearing Replacement Chart.

Bearing Lubrication - Grease

CAUTION

Do not mix Lithium, calcium, sodium or barium complex greases due to possible compatibility problems. When changing from one type of grease to another, it is necessary to insure all the old grease has been removed.

Grease should be replaced every 12,000 miles or 12 months. Prior to repacking bearings, all old grease should be removed from the wheel hub cavity and bearings. Bearings should be packed by machine if possible. If a machine is unavailable, packing by hand method is acceptable. The method to pack bearing cones is as follows:

1. Place a quantity of grease onto the palm of your hand.





2. Press a section of the widest end of bearing into the outer edge of the grease pile closest to the thumb forcing grease into the interior of the bearing between two adjacent rollers.
3. Repeat this while rotating the bearing from roller to roller.
4. Continue this process until you have the entire bearing completely filled with grease.
5. Before reinstalling, apply a light coat of grease onto the bearing cup mating surface.

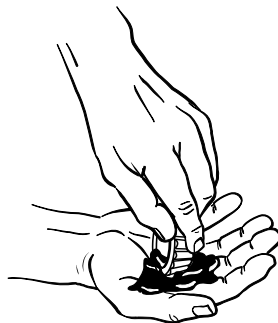

Bearing Lubrication - Oil

If your axles are equipped with oil lubricated hubs, then your lubrication procedure is to periodically fill the hub with a high quality hypoid gear oil to the level indicated on the clear plastic oil cap. The oil can be filled through the rubber plug hole in the cap. Oil should be replaced every 12 months or 12,000 miles.

Recommended Wheel Bearing Lubrication Specifications

Grease

| | |
|--------------------|---|
| Thickener Type | Lithium Complex |
| Dropping Point | 230°C (446°F) Minimum |
| Consistency | NLGI No. 2 |
| Additives | EP, Corrosion & Oxidation Inhibitors |
| Base Oil | Solvent Refined Petroleum Oil |
| Base Oil Viscosity | @ 40°C (104°F) 150cSt (695 SUS) Minimum |
| Viscosity Index | 80 Minimum |
| Pour Point | -10°C (14°F) Minimum |

Approved Grease Sources

| | |
|--|---|
| ConocoPhillips/ 76 Lubricants/Kendall | Multiplex RED #2 L427 Super Blu Grease |
| Citgo | Lithoplex MP #2 Lithoplex CM #2 Mystik JT-6 Hi-Temp Grease #2 |
| Exxon/Mobil Company | Ronex, MP Mobilith AW 2 Mobil I Synthetic Grease |
| Oil Center Research of Oklahoma | Liquid-O-Ring No, 167L |
| Pennzoil-Quaker State Company | Synthetic Red Grease |
| Shell | Gadus S3 V220C Gadus S5 V220 Rotella Heavy Duty Lithium Complex #2 |
| Royal Mfg. Company | Royal 98 Lithium Complex EP #2 |
| Chevron Texaco | Chevron Ulti-Plex Grease EP #2 Texaco Starplex Moly MPGM #2 |
| Valvoline | Valvoline Multi-Purpose GM Valvoline Durablend |
| Great Plains Lubricants | Lithium Complex EP #2 |
| Chem Arrow | Arrow 2282 |
| Chem Arrow Corp. | Arrow 2282 |





Oil

SAE 90 Hypoid Gear (Hypoid Rear Axle Oil)
(Use only with hubs equipped with oil option)

Approved Oil Sources

| | |
|--|--|
| Ashland Oil | Valvoline Dura Blend Valvoline Power Lube |
| CITGO Petroleum Co. | CITGO Premium Gear Oil MP Mystik JT-7 Mystik Power Lube |
| Exxon Company USA | Gear Oil GX 80W-90 |
| Industrial Oils Unlimited | Super MP Gear Oil 80W-90 |
| Kendall Refining Co. | Kendall NS-MP Hypoid Gear Lube |
| Lubriplate Division / Fiske Brothers Refining | Lubriplate APG 90 |
| Mobil Oil Corporation | Mobilube SHC Mobil 1 Synthetic Gear Lube |
| Phillips 66 Petroleum | Superior Multi-Purpose Gear Oil Philguard Gear Oil Philsyn Gear Oil |
| Pennzoil Products Co. | Gear Plus 80W-90 GL-5 Gear Plus Super 75W-90 Gear Plus Super EW 80W-90 Multi-Purpose 4092 Gear Lube |
| Oil Center Research | Liquid-O-Ring 750 GX |
| Sun Refining and Marketing Company | Sonoco Ultra Sonoco Dura Gear |
| Shell Oil Company | Spirax A Spirax G Spirax HD Spirax S |
| Texaco Oil Company | Multigear EP Multigear SS |
| Troco Division / Royal Manufacturing | Multigear Select Gear Oil |
| Union Oil Company | Unocal MP Gear Lube 76 Triton Syn Lube EP |

Seal Inspection and Replacement

Whenever the hub is removed, inspect the seal to assure that it is not nicked or torn and is still capable of properly sealing the bearing cavity. If there is any question of condition, replace the seal. Use only the seals specified in the Seal Replacement Chart.

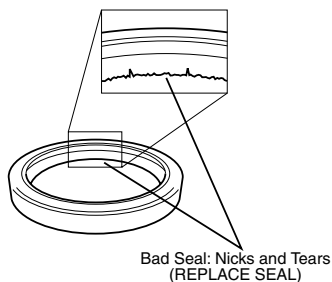

To replace the seal:

1. Pry the seal out of the hub with a seal puller. Never drive the seal out with the inner bearing as you may damage the bearing.
2. Apply a PERMATEX sealant to the outside of the new seal.

Note: Permatex sealant should not be used on rubber encased seals.

3. Install new seal into place using a seal driver.

Installation/Adjustment

For ABS installation:

1. Assure that the ABS sensor is pushed fully into its retainer clip (sensor tip is as far outboard as possible).
2. Install hub and drum squarely to the spindle centerline so that the exciter ring inside the drum will contact the sensor tip and push it back to the proper sensor to exciter ring running clearance (gap should not exceed $\frac{1}{16}$ " inch).

For non-ABS installation, begin with step 3:

3. Install the bearing and washer into the hub. Thread on the inner nut, rotate the hub and tighten the nut to **100 Ft-Lbs.** of torque.
4. Loosen the nut to remove preload torque, do not rotate hub.
5. Hand tighten the nut, then back it off $\frac{1}{4}$ to $\frac{3}{8}$ turn.
6. Place the tang washer on the spindle and bend two tangs inward over the nut. This will keep the inner nut from turning while torque is applied to the outer nut.





7. Install the outer nut and torque it to **100-175 Ft-Lbs.** Insure that the inner nut does not turn. Bend two tangs from the tang washer over the outer nut flats to secure.
8. Install cap with the O-ring and plug installed. Rotate the hub and check the bearing adjustment. The allowable end play is .001"-.010".

 **CAUTION**

FAILURE TO BACK OFF THE INNER ADJUSTING NUT COULD CAUSE BEARING AND AXLE SPINDLE OVERHEATING OR DAMAGE, WHICH COULD RESULT IN THE WHEEL LOCKING UP OR COMING OFF DURING VEHICLE OPERATION AND LEAD TO AN ACCIDENT, INJURIES OR DEATH.

 **CAUTION**

FAILURE TO TORQUE THE OUTER LOCKNUT PROPERLY COULD CAUSE THE WHEEL END TO COME OFF DURING VEHICLE OPERATION WHICH COULD RESULT IN AN ACCIDENT, INJURIES OR DEATH.

Axle & Suspension Installation

Responsibility for proper axle alignment lies with the axle installer. The axle must be installed so that it will be parallel to the drive axle(s) of the tractor. This will allow good vehicle control when cornering, longer tire wear, and it will eliminate dog tracking. Alignment can be determined by measuring from the center of the trailer king pin to the center of each end of the axles. The difference should not vary by more than $\frac{1}{16}$ ". In the case of multiple axles, the axles must also be in line with each other. The difference between the centers of one axle and end centers of the other axle must not vary more than $\frac{1}{8}$ ".

CAUTION

Safety glasses should be worn at all times when assembling or disassembling axles and their components.

Dexter tubular axles are made of high strength steel for better fatigue life and superior welding qualities. The round tubular axles provide a uniform section modulus no matter how the beam is rotated.

Brake spiders are positioned and welded to specific requirements at our factory. Welding the spider directly to the axle beam provides a higher strength and more reliable brake attachment over bolt-on versions.

In welding suspension components to a Dexter trailer axle, extreme care must be exercised to obtain correct location and ensure the spring seat load bearing surfaces are parallel to each other. Any welding of additional attachments to the axle should be approved by Dexter Axle's engineering department.





Suspension Systems

The suspension systems incorporated into Dexter axles are designed to provide the trailer owner three basic functions:

1. Attach the axle to the trailer
2. Dampen the effects of road shock
3. Provide stability to the trailer

All Dexter suspension systems are available in single and multiple axle configurations.

Slipper Leaf Springs

Slipper springs have an eye formed in one end only, with the other end formed into a reverse curve. The attachment of these springs is as follows:

1. The front eye is attached directly into the front hanger with a bolt and nut.
2. The rear end of the spring is captured in the rear hanger or equalizer with a “keeper bolt” that prevents the spring from coming out when the trailer is jacked up for service.

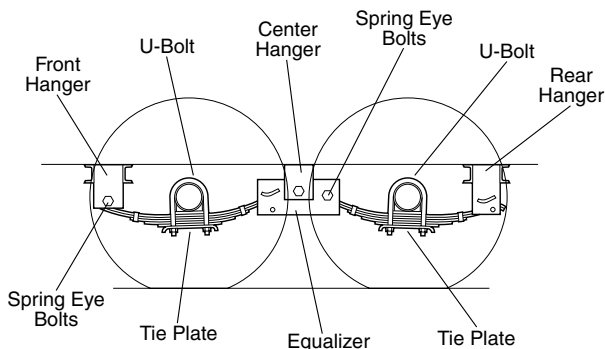

The articulation of this suspension occurs when the rear end of each slipper spring slides against the wear surfaces provided in the rear hangers or equalizers. This suspension is also available in single and multiple axle configurations.

Inspection and Replacement

All the components of your suspension system should be visually inspected least every 6,000 miles for signs of excess wear, elongation of bolt holes, and loosening of fasteners. Whenever loose or replaced, the fasteners in your suspension system should be torqued as detailed in the charts at the end of this book (Fastener Torque Values).

Worn spring eye bushings, sagging springs, or broken springs should be replaced using the following method.

CAUTION

Do not lift or support the trailer on any part of the axle or suspension system. Never go under any trailer unless it is properly supported on jack stands which have been rated for the load. Improperly supported vehicles can fall unexpectedly and cause serious injury or death.

1. Support the trailer with the wheels just off the ground. Follow the trailer manufacturer's recommendations for lifting and supporting the unit. Do not lift or place supports on any part of the suspension system.
2. After the unit is properly supported, place a suitable block under the axle tube near the end to be repaired. This block is to support the weight of the axle only so that suspension COMPONENTS can be removed.
3. Disassemble the U-bolts, nuts, and tie plates.
4. Remove the spring eye bolts and remove the spring and place on a suitable work surface.
5. If the spring eye bushings are to be replaced, press out the old bushing using a hydraulic shop press.





CAUTION

Be sure to wear safety glasses when removing or installing force fitted parts. Failure to comply may result in serious injury.

6. Lubricate the rubber bushing with liquid soap (not petroleum.) Press the new bushing into the spring eye using a hydraulic press.
7. Reinstall repaired or replaced components in reverse order.

Note: For multiple axle units, the weight of each axle must be supported as outlined in Step 2 before disassembly of any component of the suspension system.

If the equalizer or equalizer bushings must be replaced, follow the instructions above for lifting and supporting the trailer unit and then proceed as follows:

1. With both axles blocked up, remove the spring eyebolt, keeper bolt, and equalizer bolt from the equalizer to be repaired or replaced.
2. Press the old rubber bushing out of the equalizer using a hydraulic press.
3. Lubricate the replacement bushing with liquid soap and press into the equalizer.
4. Reassemble in reverse order.

CAUTION

Be sure to wear safety glasses when removing or installing force fitted parts. Failure to comply may result in serious injury.

Suspension Replacement

1. Make sure springs are on straight. Align spring eyes to front hanger. Insert spring eye bolts but do not torque at this point.
2. Assemble springs into equalizer.
3. After leveling equalizer to frame, torque equalizer nuts to values specified in Fastener Torque Specifications (Replacement Parts/Kits section).
4. Torque spring eye bolts to values specified in Fastener Torque Specifications (Replacement Parts/Kits section) for rubber bushed suspension. Torque bronze bushed suspension to snug fit only.

Torflex® Suspension

The Torflex® suspension system is a torsion arm type suspension which is completely self contained within the axle tube. It attaches directly to the trailer frame using brackets which are an integral part of the axle assembly. The Torflex® axle provides improved suspension characteristics relative to leaf spring axles, through the unique arrangement of a steel torsion bar surrounded by four natural rubber cords encased in the main structural member of the axle beam.

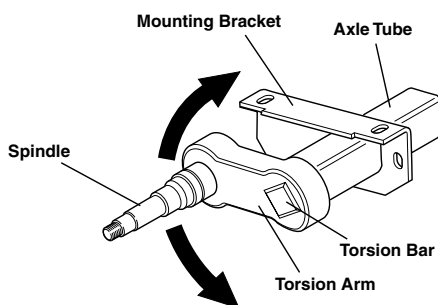

The spindle is attached to a lever, called the torsion arm, which is fastened to the rubber encased bar. As load is applied, the bar rotates causing a rolling/compressive resistance in the rubber cords. This action provides the same functions as conventional sprung axles with several operating advantages including independent suspension.

Except for periodic inspection of the fasteners used to attach the Torflex® axle to the vehicle frame, no other suspension





maintenance is required on Torflex® axles. They are, of course, subject to the maintenance and inspection procedures regarding brakes, hubs, bearings, seals, wheels, and tires, as outlined in this manual.

CAUTION

DO NOT WELD ON THE TORFLEX® BEAM. It has rubber cords inside and the heat generated by welding could damage the cords.

Wheels

Wheel Selection

Wheels are a very important and critical component of your running gear system. When specifying or replacing your trailer wheels it is important that the wheels, tires, and axle are properly matched. The following characteristics are extremely important and should be thoroughly checked when replacement wheels are considered.

1. **Bolt Circle.** Many bolt circle dimensions are available and some vary by so little that it might be possible to attach an improper wheel that does not match the axle hub. Be sure to match your wheel to the axle hub.
2. **Capacity.** Make sure that the wheels have enough load carrying capacity and pressure rating to match the maximum load of the tire and trailer.
3. **Offset.** This refers to the relationship of the center line of the tire to the hub face of the axle. Care should be taken to match any replacement wheel with the same offset wheel as originally equipped. Failure to match offset can result in reducing the load carrying capacity of your axle.
4. **Rim Contour.**



CAUTION

Replacement tires must meet the same specifications as the originals. Mismatched tires and rims may come apart with explosive force and cause personal injury to yourself or others. Mismatched tires and rims can also blow out and cause you to lose control and have an accident which can result in serious injury or death.





CAUTION

Do not attempt to repair or modify a wheel. Even minor modifications can have a great effect. Do not install a tube to correct a leak through the rim. If the rim is cracked, the air pressure in the tube may cause the pieces of the rim to explode with great force and can cause serious injury or death.

Torque Requirements

It is extremely important to apply and maintain proper wheel mounting torque on your trailer axle. Torque is a measure of the amount of tightening applied to a fastener (nut or bolt) and is expressed as length times force. For example, a force of 90 pounds applied at the end of a wrench one foot long will yield **90 Ft. Lbs.** of torque. Torque wrenches are the best method to assure the proper amount of torque is being applied to a fastener.

CAUTION

Wheel nuts or bolts must be tightened and maintained at the proper torque levels to prevent loose wheels, broken studs, and possible dangerous separation of wheels from your axle, which can lead to an accident, personal injuries or death.

Be sure to use only the fasteners matched to the cone angle of your wheel (usually 60° or 90°.) The proper procedure for attaching your wheels is as follows:

1. Start all bolts or nuts by hand to prevent cross threading.
2. Tighten bolts or nuts in the following sequence.
3. The tightening of the fasteners should be done in stages. Following the recommended sequence, tighten fasteners per wheel torque requirements diagram.

4. Wheel nuts/bolts should be torqued before first road use and after each wheel removal. Check and re-torque after the first 50 miles and again at 100 miles. Check periodically thereafter.

Wheel Torque Sequence

| Description | Part No. | Application | Torque Min Ft-Lbs. | Torque Max Ft-Lbs. |
|------------------------|----------------------------------|----------------------------|--------------------|---------------------------|
| 5/8-18 90° Cone Nut | 006-109-00 | Clamp Ring 033-052-01 | 190 | 210 Greased Threads |
| 3/4-10 Hex Nut | 006-117-00 | Demountable Rim Clamp | 210 | 260 |
| 3/4-16 Spherical Nut | 006-064-01, 02 006-069-01, 02 | Single Wheel Inner Dual | 450 450 | 500 500 |
| 1 1/8-16 Spherical Nut | 006-070-01, 02 | Outer Dual | 450 | 500 |
| 5/8-18 Flange Nut | 006-058-00 | Wheels | 275 | 325 |
| M22-1.5 | 006-118-00 | Swivelling Flangenut | 450 | 500 |

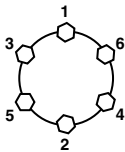

6 BOLT

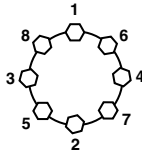

8 BOLT

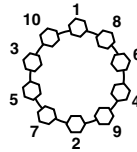

10 BOLT





Tires

Before mounting tires onto wheels, make certain that the rim size and contour is approved for the tire as shown in the Tire and Rim Association Yearbook or the tire manufacturers catalog. Also make sure the tire will carry the rated load. If the load is not equal on all tires due to trailer weight distribution, use the tire rated for the heaviest wheel position.







Use tire mounting procedures as outlined by the Rubber Manufacturers Association or the tire manufacturers.

Tire inflation pressure is the most important factor in tire life. Inflation pressure should be as recommended by the manufacturer for the load. Pressure should be checked cold before operation. Do not bleed air from tires when they are hot. Check inflation pressure weekly during use to insure the maximum tire life and tread wear. The following tire wear diagnostic chart will help you pinpoint the causes and solutions of tire wear problems.

CAUTION

Proper matching of the tire/wheel combination is essential to proper function of your trailer running gear. Some tires may call for a maximum inflation pressure above the rim or wheel capacity. DO NOT EXCEED MAXIMUM INFLATION PRESSURES FOR RIMS OR WHEELS. Catastrophic failure may result.

Tire Wear Diagnostic Chart

| Wear Pattern | | Cause | Action |
|---|--------------------|-------------------------------|---|
|  | Center Wear | Over Inflation | Adjust pressure to particular load per tire catalog |
|  | Edge Wear | Under Inflation | Adjust pressure to particular load per tire catalog |
|  | Side Wear | Loss of camber or overloading | Make sure load doesn't exceed axle rating. Align at alignment shop. |
|  | Toe Wear | Incorrect toe-in | Align at alignment shop. |
|  | Cupping | Out-of-balance | Check bearing adjustment and balance tires. |
|  | Flat Spots | Wheel lockup & tire skidding | Avoid sudden stops when possible and adjust brakes. |

CAUTION

Tire wear should be checked frequently. Once a wear pattern becomes firmly established in a tire it is difficult to stop, even if the underlying cause is corrected.





Replacement Parts/Kits

Fastener Torque Specifications

| Description | Application | Part No. | Min Torque Ft. Lbs. | Max Torque Ft. Lbs. |
|-------------------------------|--|-------------------------------------|---------------------|---------------------|
| Spindle Nut Inner Outer | 9-15K 9-15K | See Bearing Installation/Adjustment | | |
| Grease Zerk | Cam Bushing Spider | | 5 8 | 15 8 |
| Cam Brackets | | | 3 | 4 |
| Air Chamber | 12-15K Air Brake | | 50 | 55 |
| 5/8-11 Hex Locknut | 9K, 10K, U-Bolt | 006-038-00 | 110 | 150 |
| 1/2-13 Hex Head Cap Screw | Drum Mounting 10-15K | 007-244-00 | 90 | 110 |
| 1/2-13 Hex Cap Screw | Drum Mounting 10K GD | 007-245-00 | 90 | 110 |
| 5/8-11 Hex Locknut | 9K Spring Eye | 006-038-00 | 130 | 150 |
| 1-8 Hex Locknut | 9K Equalizer | 006-112-00 | 325 | 375 |
| 1-8 Hex Locknut | 10K GD Equalizer | 006-112-00 | 325 | 375 |
| 3/4-10 Hex Locknut | 10K GD Spring Eye | 006-113-00 | 200 | 250 |
| 3/4-10 Hex Locknut | 12K, 15K U-Bolt | 006-113-00 | 130 | 170 |
| 1-8 Hex Locknut | 10K, 12-15K Spring Eye Rubber Bushed | 006-112-00 | 275 | 325 |
| 1 1/8-7 Hex Locknut | 10K, 12-15K Equalizer Rubber Bushed | 006-072-00 | 350 | 400 |
| Plastic Oil Cap | Oil Hubs | 021-035-00 021-036-00 | 20 | 30 |
| 7/16-20 Hex Nut | Brake Mounting | 006-017-00 | 55 | 80 |

Replacement Parts/Kits

Bearing Replacement Chart

| Axle | Inner Bearing | | Outer Bearing | |
|------------|---------------|--------------|---------------|--------------|
| | Dx. No. | Industry No. | Dx. No. | Industry No. |
| 9K, 10K GD | 031-019-01 | 382A | 031-030-11 | 25520 |
| | 031-019-02 | 387A | 031-030-12 | 25580 |
| 10K HD | 031-022-01 | 394A | 031-019-01 | 382A |
| | 031-022-02 | 395S | 031-019-02 | 387A |
| 12K | 031-020-01 | 3920 | 031-021-01 | 28622 |
| | 031-020-02 | 3984 | 031-021-02 | 28682 |
| 15K | 031-020-01 | 3920 | 031-021-01 | 28622 |
| | 031-020-02 | 3984 | 031-021-02 | 28682 |

Seal Replacement Reference

| Axle | Part Number | Kit Number |
|--------|-------------|------------|
| 9K | 010-051-01 | K71-387-00 |
| 10K GD | 010-051-01 | K71-387-00 |
| 10K HD | 010-056-00 | K71-388-00 |
| 12K | 010-056-00 | K71-388-00 |
| 15K | 010-056-00 | K71-388-00 |

Electric Brake Magnets

| Brake Size | Magnet Kit Number (one magnet per kit) | Wire Color |
|--------------------|---|------------|
| 12¼" x 3⅜" 9K, 10K | K71-376-00 | Yellow |
| 12¼" x 4" 10K | K71-376-00 | Yellow |
| 12¼" x 5" 12K | K71-377-00 | Black |
| 12¼" x 5" 15K | K71-378-00 | Blue |





Brake Shoe Replacement Kits

| Brake Size | Description | Shoe and Lining Replacement |
|-------------------|--|--|
| 12¼" x 3⅝" | Electric Cast Back Plate Electric Stamped Back Plate Hydraulic | K71-499-00 LH; K71-498-00 RH K71-049-00 LH; K71-050-00 RH K71-165-00 LH; K71-166-00 RH |
| 12¼" x 4" | Electric Cast Back Plate Electric Stamped Back Plate Hydraulic | K71-501-00 LH; K71-500-00 RH K71-051-00 LH; K71-052-00 RH K71-167-00 LH; K71-168-00 RH |
| 12¼" x 5" | Electric Cast Back Plate Electric Stamped Back Plate Hydraulic | K71-503-00 LH; K71-502-00 RH K71-053-00 LH; K71-054-00 RH K71-169-00 LH; K71-170-00 RH |

Air Brake Shoe & Linings

| Axle Model | Brake Size | Shoe & Lining No. (2 Required per Brake) |
|-------------------|-------------------|---|
| 10K HD | 12¼" x 4" | 040-321-01 |
| 12K, 15K | 12¼" x 5" | 040-322-01 |

Air Brake Repair Kits

| Description | Axle Model | Kit Number |
|----------------------------------|-------------------|-------------------|
| Camshaft PQ Style Repair Kit | 10-15K | K71-101-00 |
| Brake Shoe PQ Style Hardware Kit | 10-27K | K71-460-00 |

Disc Brake Pad Kit

| Axle Model | Kit Number |
|-------------------|-------------------|
| 10K or 12K | K71-180-00 |

Disc Brake Caliper Repair Kit

| Axle Model | Kit Number |
|-------------------|-------------------|
| 10K or 12K | K71-181-00 |

Storage

Storage Preparation

If your trailer is to be stored for an extended period of time or over the winter, it is important that the trailer be prepared properly.

1. Remove the emergency breakaway battery and store inside, out of the weather. Charge the battery at least every 90 days.
2. Jack up the trailer and place jack stands under the trailer frame so that the weight will be off the tires. Follow trailer manufacturer's guidelines to lift and support the unit. Never jack up or place jack stands on the axle tube or on the equalizers.

CAUTION

Do not lift or support the trailer on any part of the axle or suspension system. Never go under any trailer unless it is properly supported on jack stands which have been rated for the load. Improperly supported vehicles can fall unexpectedly and cause serious injury or death.

3. Lubricate mechanical moving parts such as the hitch, and suspension parts, that are exposed to the weather.
4. Boat trailer axles are subject to repeated immersion. Before storing, remove brake drums; clean, dry and re-lubricate moving brake components; inspect bearings - clean and re-lubricate.
5. On oil lubricated hubs, the upper part of the roller bearings are not immersed in oil and are subject to potential corrosion. For maximum bearing life, it is recommended that you revolve your wheels periodically (every 2-3 weeks) during periods of prolonged storage.





After Prolonged Storage Inspection Procedure

Before removing trailer from jack stands:

1. Remove all wheels and hubs or brake drums. Note which spindle and brake that the drum was removed from so that it can be reinstalled in the same location.
2. Inspect suspension for wear.
3. Check tightness of hanger bolt, shackle bolt, and U-bolt nuts per recommended torque values.
4. Check brake linings, brake drums and armature faces for excessive wear or scoring.
5. Check brake magnets with an ohmmeter. The magnets should check 3.2 ohms. If shorted or worn excessively, they must be replaced.
6. Lubricate all brake moving parts using a high temperature brake lubricant (LUBRIPLATE or Equivalent).

CAUTION

Do not get grease or oil on brake linings or magnet face.

7. Remove any rust from braking surface and armature surface of drums with fine emery paper or crocus cloth. Protect bearings from contamination while so doing.
8. Inspect oil or grease seals for wear or nicks. Replace if necessary.
9. Lubricate hub bearings. Refer to procedure in manual.
10. Reinstall hubs and adjust bearings per instructions in manual.
11. Mount and tighten wheels per instructions in manual.

Trip Preparation Checklist

There are a number of simple rules to follow in caring for your trailer axle assembly that can add to its life and in the case of some of these rules, you may be protecting your own life as well.

Using the following checklist before starting a trip with your trailer is highly recommended. Some of these items should be checked 2-3 weeks prior to a planned trip to allow sufficient time to perform maintenance.

1. Check your maintenance schedule and be sure you are up-to-date.
2. Check hitch. Is it showing wear? Is it properly lubricated?
3. Fasten safety chains and breakaway switch actuating chain securely. Make certain the breakaway battery is fully charged.
4. Inspect towing hookup for secure attachment.
5. Load your trailer so that approximately 10% of the trailer's total weight is on the hitch. For light trailers this should be increased to 15%. Fifth wheel type trailer should have 15-25% weight on the hitch.
6. **Do Not Overload.** Stay within your gross vehicle rated capacity (consult your trailer's identification plate).
7. Inflate tires according to manufacturer's specifications; inspect tires for cuts, excessive wear, etc.
8. Check wheel mounting nuts/bolts with a torque wrench. Torque in proper sequence, to the levels specified in this manual.
9. Make certain the brakes are synchronized and functioning properly.
10. Check tightness of hanger bolt, shackle bolt, and U-bolt nuts per torque values specified in manual.
11. Check operation of all lights.
12. Check that your trailer is towing in a level position and adjust hitch height if required.





Dexter Axle Limited Warranty

WHAT PRODUCTS ARE COVERED

All Dexter Axle Company (“Dexter Axle”) trailer axles, suspensions, and brake control systems excluding Dexter 6000 series Manufactured Housing Axles.

LIMITED 2 YEAR WARRANTY

Dexter Axle warrants to the original purchaser that its axles, suspension systems, and E/H hydraulic brake actuators shall be free from defects in material and workmanship for a period of two (2) years from the date of first sale of the trailer incorporating such components.

LIMITED 5 YEAR WARRANTY

Dexter Axle warrants to the original purchaser that its Nev-R-Lube® bearings and the suspension components only, of its Torflex® Axles shall be free from defects in material and workmanship for a period of five (5) years from the date of first sale of the trailer incorporating such components.

LIMITED 7 YEAR WARRANTY

Dexter Axle warrants to the original purchaser that its Predator Series® electric brake controllers shall be free from defects in material and workmanship for a period of seven (7) years from the date of purchase.

EXCLUSIVE REMEDY

Dexter Axle will, at its option, repair or replace the affected components of any defective axle, repair or replace the entire defective axle, or refund the then-current list price of the axle. In all cases, a reasonable time period must be allowed for warranty repairs to be completed. Allowance will only be made for installation costs specifically approved by Dexter Axle.

WHAT YOU MUST DO

In order to make a claim under these warranties:

1. You must be the original purchaser of the vehicle in which the spring suspension axles or Torflex® axles were originally installed.
2. You must promptly notify us within the warranty period of any defect, and provide us with the axle serial number and any substantiation which may include, but is not limited to, the return of part(s) that we may reasonably request.

3. The axles or suspensions must have been installed and maintained in accordance with good industry practice and any specific Dexter Axle recommendations, including those specified in Dexter Axle's publication "Operation Maintenance Service Manual."

EXCLUSIONS

These warranties do not extend to or do not cover defects caused by:

1. The connecting of brake wiring to the trailer wiring or trailer wiring to the towing vehicle wiring.
2. The attachment of the running gear to the frame.
3. Hub imbalance, or any damage caused thereby.
4. Parts not supplied by Dexter Axle.
5. Any damage whatever caused by or related to any alteration of the axle including welding supplemental brackets to the axle.
6. Use of an axle on a unit other than the unit to which it was originally mounted.
7. Normal wear and tear.
8. Alignment.
9. Improper installation.
10. Unreasonable use (including failure to provide reasonable and necessary maintenance as specified in Dexter Axle's publication "Operation Maintenance Service Manual" including required maintenance after "Prolonged Storage").
11. Improper wheel nut torque.
12. Cosmetic finish or corrosion.

LIMITATIONS

1. **In all cases, Dexter Axle reserves the right to fully satisfy its obligations under the Limited Warranties by refunding the then-current list price of the defective axle (or, if the axle has been discontinued, of the most nearly comparable current product).**
2. Dexter Axle reserves the right to furnish a substitute or replacement component or product in the event an axle or any component of the axle is discontinued or is otherwise unavailable.
3. These warranties are nontransferable.





GENERAL

THE FOREGOING WARRANTIES ARE EXCLUSIVE AND IN LIEU OF ALL OTHER WARRANTIES EXCEPT THAT OF TITLE, WHETHER WRITTEN, ORAL OR IMPLIED, IN FACT OR IN LAW (INCLUDING ANY WARRANTY OF MERCHANTABILITY OR FITNESS FOR A PARTICULAR PURPOSE).

These warranties give you specific legal rights, and you may also have other rights which vary from state to state.

DEXTER AXLE HEREBY EXCLUDES INCIDENTAL AND CONSEQUENTIAL DAMAGES, INCLUDING LOSS OF TIME, INCONVENIENCE, LOSS OF USE, TOWING FEES, TELEPHONE CALLS OR COST OF MEALS, FOR ANY BREACH OF ANY EXPRESS OR IMPLIED WARRANTY.

Some states do not allow limitations on how long an implied warranty lasts, or the exclusion or limitation of incidental or consequential damages, so the above exclusion or limitation may not apply to you.

Inquiries regarding these warranties should be sent to:

Dexter Axle Company
P.O. Box 250
Elkhart, Indiana 46515

Axle Identification

In the unlikely event that you should require service assistance from Dexter Axle, please have the lot number of the axle available when you call.

On all axles produced after April 2001, this nine digit number can be found on the rear side of the axle beam approximately 18" from the curb side of the vehicle. Look for the words DEXTER AXLE and the lot number will be located directly under the name.



Dexter Online Parts Store

From magnets and seals to complete brake and hub kits, Dexter offers a complete line of genuine replacement parts for your trailer. Most products are available in-stock and ready to ship within 24 hours direct to you from the factory. With dedicated customer support, quick turnaround and a 30-day money back guarantee, the Dexter Online Parts Store helps keep your trailer going.

- Hub Components
- Brake Components
- Suspension Components
- Complete Hub Kits
 - Brake Assemblies & Kits
 - Brake Controllers & Actuators



**Ready for Immediate Shipment
Direct to Your Door**

Visit us online at www.dexteraxle.com

Genuine Dexter axles and components are available nationwide from our plant locations listed below or through our network of distributors. Check our web site for the distributor nearest you.

Visit us online at www.dexteraxle.com

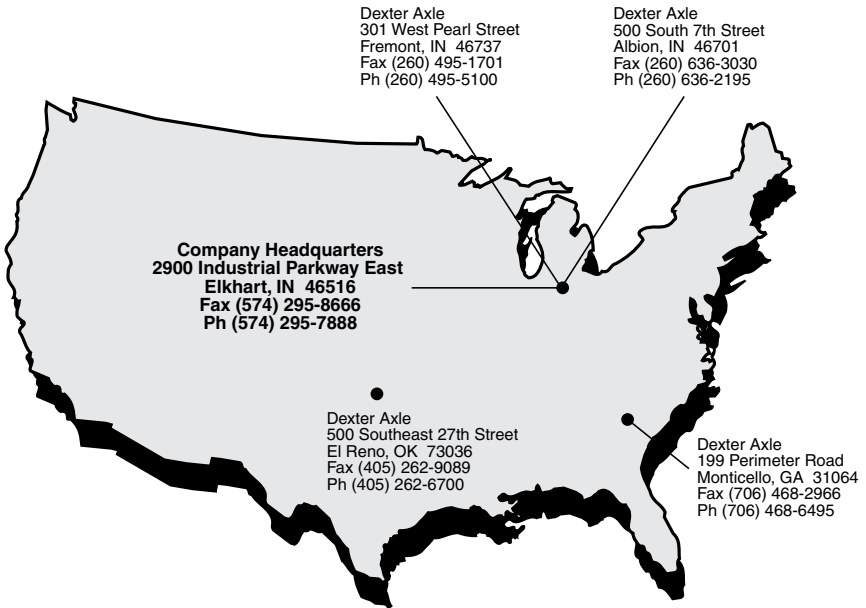

NO PART OF THIS CATALOG MAY BE REPRODUCED WITHOUT DEXTER AXLE'S PERMISSION.
ALL PART NUMBERS, DIMENSIONS AND SPECIFICATIONS IN THIS CATALOG ARE SUBJECT
TO CHANGE WITHOUT NOTICE.

GEARED FOR INNOVATION SINCE 1960



www.dexteraxle.com

2900 Industrial Parkway East ■ Elkhart, IN 46516

Phone: 574-295-7888 ■ Fax: 574-295-8666

