



DEXTER AXLE

www.dexteraxle.com

22,500 – 27,500 LBS. CAPACITY



OPERATION MAINTENANCE SERVICE MANUAL

Introduction

This manual is designed to provide information for you to understand, use, maintain, and service your trailer running gear system. Your axles are manufactured by Dexter Axle. Since 1960, Dexter's experience in the design, testing, and manufacturing of trailer axles has resulted in the most complete product line in the industry. The Dexter running gear system consists of axles, suspensions, and braking systems which are engineered to provide you the finest towing and stopping performance currently available today.

Two Dexter philosophies are at work to provide you the best product available and have enabled us to maintain our position of leadership. First, we operate on the theory that "there is always a better way" for a product to operate, to be manufactured, and/or to be serviced. We are constantly striving to find that better way.

Secondly, we maintain wall-to-wall production control so that all the major components of your running gear system are manufactured in Dexter facilities under our strict quality control standards. These manufactured components include axle beams, hubs, drums, spindles, and braking systems, as well as the components used in the attachment of the axle to the chassis. Dexter has the most complete, state-of-the-art manufacturing facilities which enable us to provide you, the trailer owner, with the finest product possible.

For all your running gear needs...

Look first to Dexter!

**Visit us online at
www.dexteraxle.com**



Introduction

Important Safety Notice3

Installation

Installation4

Welding

General Welding Recommendations5
Axle Beam Repair Welding5
Preheating Recommendations5
How Welding Affects Axle Beam Material5
Welding Guide6
Stress of Axle Beams6
Spring Seat Placement and Location7
Weld Placement Recommendation9

Wheel Bearings

Wheel Bearings11
Grease Lubrication11
Oil Lubrication12
Adjustment12
Recommended Wheel Bearing Lubrication Specs13

Brake Adjustment

Recommended Brake Adjustment Procedure16

Brake Assembly/Disassembly

Recommended Brake Assembly/Disassembly18
16½" x 7" Brakes18
12¼" x 7½" - P Style20
12¼" x 7½" - PQ Style21

Brake Component Lubrication

Brake Component Lubrication24
Lubrication Guidelines24
Frequency of Service24

Maintenance

Suggested Preventative Maintenance25
Every 1,000 Miles25
Every 12,000 Miles25
Every 25,000 to 30,000 Miles25
Every 100,000 Miles, Once a Year, or at Brake Reline25

Specifications

Fastener Specifications Chart26

Replacement Parts/Kits

Replacement Parts/Kits27
Brake Shoe Hardware Kits27
Brake Block Kits27
Camshaft Repair Kits27
Shoe & Block Assemblies27

Warranty

Dexter Axle Limited Warranty28

Axle Identification

Axle Identification31

Important Safety Notice

Appropriate service methods and repair procedures are essential for the safe, reliable operation of all running gear as well as the personal safety of the individual doing the work. This manual provides general directions for performing service and repair work with tested, effective techniques. Following these guidelines will help assure reliability.

There are numerous variations in procedures, techniques, tools, parts for servicing axles, as well as in the skill of the individual doing the work. This manual cannot possibly anticipate all such variations and provide advice or cautions as to each. Anyone who departs from the instructions provided in this manual must first establish that they neither compromise their personal safety nor the vehicle integrity by their choice of methods, tools, or parts.

Refer to your vehicle manufacturer's owners manual for additional procedures, techniques, and warnings prior to performing any maintenance or repairs.



CAUTION

This is the safety alert symbol. It is used to alert you to potential injury hazards. Obey all safety messages that follow this symbol to avoid possible injury or death.





Installation

To assure safe operation and maximum durability of parts such as brake linings and tires, it is necessary to position and install the axle properly. It is recommended that the axle assembly be installed so that camshafts rotate in the same direction as the wheels. Installation in which the camshaft rotation is opposite that of wheel rotation could cause noisy brakes, chatter, and wheel "hop". With this thought in mind, the axle should be ordered with placement of air chamber and slack adjuster assemblies that will ensure the correct directional rotation of the camshafts when the axle is installed (see page 8).

It is the responsibility of the axle installer to adjust the brakes properly. The recommended adjustment procedure is covered in the section pertaining to brakes.

Responsibility for proper axle alignment lies with the axle installer. The axle must be installed so that it will be parallel to the drive axle(s) of the tractor. This will allow good vehicle control when cornering, longer tire wear, and it will eliminate dog tracking. Alignment can be determined by measuring from the center of the trailer king pin to the center of each end of the axles. The difference should not vary by more than $\frac{1}{16}$ ". In the case of multiple axles, the axles must also be in line with each other. The difference between the centers of one axle and the centers of the other axle must not vary more than $\frac{1}{8}$ ".

General Welding Recommendations

Dexter tubular axles are made of high strength steel for better fatigue life and superior welding qualities. The round tubular axles provide a uniform section modulus no matter how the beam is rotated.

Brake spiders are positioned and welded to exacting specification requirements at our factory. Ring welding the spider directly to the axle beam provides a higher strength and more reliable brake attachment over bolt-on versions.

In welding suspension component parts to a Dexter trailer axle, extreme care must be exercised to obtain correct location and ensure the spring seat load bearing surfaces are parallel to each other.

Axle Beam Repair Welding

In the interest of safety and preserving the service life of trailer axle assemblies, Dexter recommends that trailer axle beams NOT be repair welded. Repair welding can detract from the structural integrity of an engineered component, particularly on heat-treated parts where the benefit of the processing may be nullified by the welding. Therefore, a new replacement beam should be installed as soon as possible.

Preheating Recommendations

Absolutely no welding should be done on axles that are below 50°F. Before welding on suspension components or any other part onto the axle, the area (within 3") of the attachment point should be warmed slowly to between 500-600°F. Immediately after checking the temperature with an appropriate temperature sensitive crayon, the part(s) should be tack welded in place. Recheck the temperature and if below 475°F, reheat to 500-600°F and complete welding per welding instructions.

How Welding Affects Axle Beam Material

All welds made on the beam create, in effect, an extremely localized heat-treatment of the metal. The heat generated





during the welding process can cause the material in the HAZ (heat affected zone) to become hardened or brittle. This effect can impart an undesirable characteristic to the normally ductile structure. This small hardened area becomes the weakest part of the beam and therefore is the area most susceptible to failure. The axle beam is no stronger than its weakest section. As evident from the sketch on page 9, the welds should be horizontal and as near as possible to the front and rear horizontal center line of the axle beam. Always avoid welds that are circumferential in nature below the horizontal center line.

Welding Guide

Dexter supplies axles to customers in all stages of assembly from the beam with spindles only, to the complete axle assemblies. In the final analysis and with few exceptions, we have little or no control over later assembly of incomplete units by the trailer fabricator and, therefore, we can not be responsible for warranty on improperly processed components.

Stress of Axle Beams

The main loaded stresses on a beam are expressed as three primary stress zones. The compression stress zone (top side), the tension stress zone (bottom side), and the neutral stress zone (front and rear horizontal center line commonly referred to as the neutral axis).

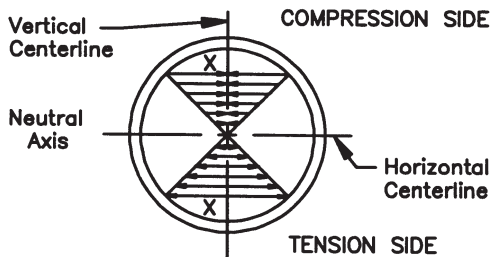

The above is a graphic representation of the degrees of stress in the wall of the tube when the beam is under load. The length of the arrows "X" represents the amount of stress at a given point.

From this illustration, it is evident that the two opposite stresses diminish as the horizontal center line of the beam is approached.

In addition, the torsional stress imparted by braking action of the wheels is taken into consideration in rating the axle capacity. An allowance of both stresses bending (beam load) and torsional are factored into the calculations to provide an acceptable design factor. The stresses are reapplied and reversed many times during normal axle beam life. For this reason, the beam material must have certain properties such as impact strength, that permit it to absorb shock, to flex, and then to resume its original and normal "as manufactured" condition.

When welding, it is necessary to avoid the high stress areas on the tube top side (compression zone) and tube bottom side (tension zone). All welds should be made as close to the horizontal center line as possible. When the axle tube is subjected to the heat from welding and then rapid cooling, the material adjacent to the weld loses its desirable ductile properties and becomes brittle. If this condition exists in the high stress areas under maximum load conditions, the life of the axle will be greatly reduced and premature fatigue failure can occur. Recommended locations for the welds are shown below.

Spring Seat Placement and Location

One of the most critical and important phases of vehicle fabrication is the placement, location, and attachment of spring seats on the axle.

"Overhang" is defined as axle track minus spring center dimension divided by two:

$$\frac{T - S.C.}{2}$$

The maximum spring center is calculated such that recommended inside of tire or drum clearance to vehicle frame is achieved.

Permanent deformation and/or premature failure of the axle may result if the spring centers are too narrow.



Welding



To assure welds are within approved neutral axis zone quadrants
Maximum rotation of camshaft position is +6° up to -6° down from 0° neutral axis.

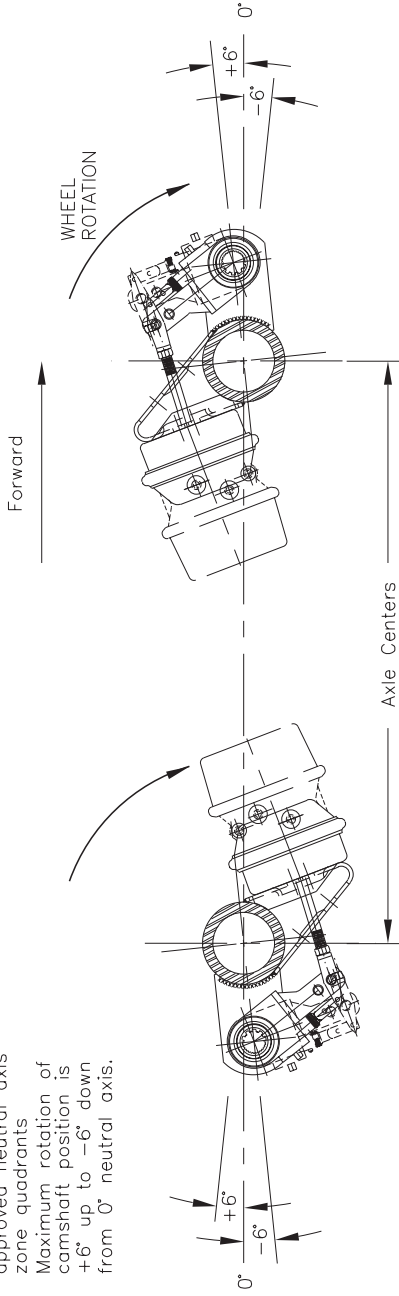

MOST COMMON FOR OVER-THE-HIGHWAY OPERATIONS.

Weld Placement Recommendation for Welding Spring Seats to Round Axles

Note: If spring seat and related U-bolt clamp parts are different than shown, refer or consult with suspension manufacturer for weld recommendations.

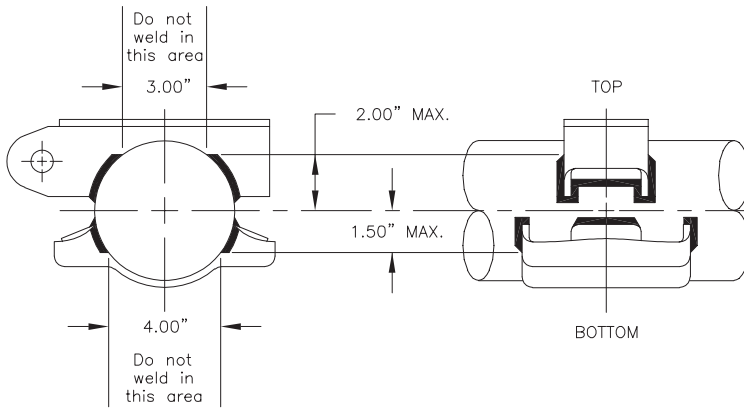

The welding rods should conform to AWS (American Welding Society), grade E-7018 (Oven-Dried) or comparable. Recommended rod size is $\frac{5}{32}$ " at voltage and amperage recommended by the electrode manufacturer. For maximum strength, a three-pass weld should be used. The arc should not be broken at the end of each pass and the corners should be wrapped. The electrode should be backed up to fill in the crater at the end of each pass. If the arc is broken between passes, thoroughly clean the weld between each pass.

Process	Electrode
Shielded metal-arc welding of carbon and low alloy steels.	A.W.S.* E70XX
Gas metal-arc welding of carbon and low alloy steels.	A.W.S.* ER70S-X
Submerged arc welding of mild and low alloy steels.	A.W.S.* F-72-XXXXX

*American Welding Society





CAUTION

Do not bring axles in from non-heated storage and weld while cold. Do not “test the arc” on the axle beam.

Fillets up to 1/2" can be used. Maximum gap .030 inch. The attachments should fit-up as close to the beam as possible to avoid excessive welding. Electrical grounding to the axle for welding purposes, should be done on one of the attachments such as the air chamber bracket, cam support, or brake spider. Connections should be clean and tight. Loose or dirty connections will cause arcing at that point during welding. These small arced areas can create the potential for failure in highly stressed structures. Therefore, grounding should never be done directly on the axle tube. Never attach the ground to an area that would allow the ground path to pass through the spindles, bearings, hub, or wheel components.

CAUTION

To provide optimum suspension-to-tube welds, preheating is recommended. Preheating will minimize loss of the ductile properties in the weld area by slowing the rate of cooling, thus reducing the formation of an untempered martensitic grain structure adjacent to the weld. Martensite, a brittle grain structure, is formed by the rapid cooling of the metal surrounding the weld area. Preheat the suspension seat weld area to 500-600°F prior to welding. Preheated temperature should be verified with a temperature sensitive crayon or appropriate means.

The above welding recommendation pertains to all Dexter Axle Company axle beams. Unapproved variation from the procedures listed will void the axle warranty and could result in an unsafe weld.

Wheel Bearings

Periodic inspection and regular replacement of lubricant is important to obtain maximum bearing life. Always inspect bearings for damage prior to installation. When installing wheel bearings, it is important to ensure both the inside of the wheel hub cavity, bearings and grease cap are clean. It is also recommended that seals be replaced when wheel hubs have been removed for service. **EXTREME CARE SHOULD BE TAKEN WHEN REINSTALLING WHEEL HUBS TO PREVENT DAMAGE TO THE SEALS. DO NOT CONTACT RUBBER SEALING LIP WITH THE SPINDLE THREADS.**

Grease Lubrication

Grease should be replaced every 12,000 miles or 12 months. Prior to repacking bearings, all old grease should be removed from the wheel hub cavity and bearings. Bearings should be packed by machine. If machine is unavailable, packing by hand method is acceptable. The method to pack bearing cones is as follows:

1. Place a quantity of grease onto the palm of your hand.
2. Press a section of the widest end of bearing into the outer edge of the grease pile closest to the thumb, forcing grease into the interior of the bearing between two adjacent rollers.
3. Repeat this while rotating the bearing from roller to roller.
4. Continue this process until you have the entire bearing completely filled with grease.
5. Before reinstalling, apply a light coat of grease onto the bearing cup mating surface.

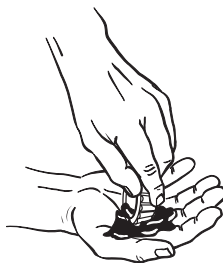



Oil Lubrication

Oil should be changed at least once a year, or 100,000 miles, or whenever the seals or brakes are replaced. Oil level should be inspected every 1,000 miles. Always allow a few minutes, after adding oil or after vehicle operation, for the oil to settle when establishing the required oil level.

Adjustment

1. After properly installing the bearings and seals according to the manufacturer's recommendations, tighten the inner spindle nut to **100 Ft. Lbs.** while rotating the hub to ensure proper seating of the bearings, cups and seal in the wheel hub.

CAUTION

You must follow the maintenance procedures to prevent damage to important structural components. Damage to certain structural components such as wheel bearings can cause the wheel end to come off of the axle. Loss of a wheel end while the trailer is moving can cause you to lose control and lead to an accident, which can result in serious injury or death.

2. Loosen the inner spindle nut to remove pre-load torque.
3. Hand tighten the inner adjustment nut, then back off $\frac{1}{4}$ turn, $\frac{3}{8}$ turn maximum.
4. Install lock ring (lock ring must engage pin on inner spindle nut. Nut to engage nearest pin hole).
5. Install tab washer and outer locknut. Torque outer spindle nut to **250-300 Ft. Lbs.** Bend 3 tabs over outer nut flats to secure.
6. This procedure should assure an end-play of .001" to .010" which must be present in the adjusted wheel bearing assembly.

Recommended Wheel Bearing Lubrication Specifications

Grease:

Thickener Type	Lithium Complex
Dropping Point	215°C (419°F) Minimum
Consistency	NLGI No. 2
Additives	EP, Corrosion & Oxidation Inhibitors
Viscosity Index	80 Minimum

Approved Grease Sources:

76 Lubricants Company	76 Multiplex EP 76 Multiplex RED
Citgo Petroleum Corp.	Lithoplex MP #2 Lithoplex CM #2
Exxon Company, USA	Ronex, MP
Kendall Motor Oil (Div. of Witco Corp.)	Kendall Super Blu L427 Grease
Mobil Oil Company	Mobil Grease HP Mobilith AW 2 Mobil I Synthetic Grease
Mystik Oil Company Inc.	Mystik JT-6 Hi-Temp Grease Red Lithium Complex EP No. 2 Mystik SX-6 Synthetic Blend Extreme Range, Low Temp Blue Lithium Complex
Oil Center Research of Oklahoma	Liquid-O-Ring No, 167L
Pennzoil-Quaker State Company	Synthetic Red Grease
Shell	Gadus S3 V220C Gadus S5 V220 Rotella Heavy Duty Lithium Complex #2





Royal Mfg. Company	Royal 98 Multi-Lube EP #2 Lithium Complex
Chevron Texaco	Chevron Ulti-Plex Grease EP NLGI 2 Texaco Starplex Moly MPGM 2
Chem Arrow Corp.	Arrow 78981-1
Valvoline (Div. of Ashland Inc.)	Valvoline Multi-Purpose GM
Great Plains Lubricants	Lithium Complex EP Grease NLGI 2

Oil:

SAE 90, SAE 80W-90, SAE 75W-90

Approved Oil Sources:

Ashland Oil	Valvoline Dura Blend Valvoline Power Lube
CITGO Petroleum Co.	CITGO Premium Gear Oil MP Mystik JT-7 Mystik Power Lube
Exxon Company USA	Gear Oil GX 80W-90
Industrial Oils Unlimited	Super MP Gear Oil 80W-90
Kendall Refining Co.	Kendall NS-MP Hypoid Gear Lube
Lubriplate Division / Fiske Brothers Refining	Lubriplate APG 90
Mobil Oil Corporation	Mobilube SHC Mobil 1 Synthetic Gear Lube
Phillips 66 Petroleum	Superior Multi-Purpose Gear Oil Philguard Gear Oil Philsyn Gear Oil
Pennzoil Products Co.	Gear Plus 80W-90 GL-5 Gear Plus Super 75W-90 Gear Plus Super EW 80W-90 Multi-Purpose 4092 Gear Lube
Oil Center Research	Liquid-O-Ring 750 GX
Sun Refining and Marketing Company	Sonoco Ultra Sonoco Dura Gear

Wheel Bearings

Shell Oil Company	Spirax A Spirax G Spirax HD Spirax S
Texaco Oil Company	Multigear EP Multigear SS
Troco Division / Royal Manufacturing	Multigear Select Gear Oil
Union Oil Company	Unocal MP Gear Lube 76 Triton Syn Lube EP





Recommended Brake Adjustment Procedure

1. Grease cam bracket and spider fittings.

CAUTION

Care must be exercised to prevent grease from coming in contact with brake linings which could result in reduced braking performance.

2. Adjust the slack adjuster until the brake lining comes into contact with the brake drum.
 - A. For green brakes*, there should be a slight amount of wheel drag at initial adjustment to compensate for any lining irregularities (high spot, etc.)
 - B. For burnished or broken-in brakes, back off the slack adjuster to achieve .030" clearance between drum and shoes.
3. Apply brakes using normal truck operating pressure (average line pressure should be 90 psi.)

CAUTION

USE OF AIR PRESSURE IN EXCESS OF 130 PSI COULD RESULT IN FAILURE OF THE AIR CHAMBER OR SPRING BRAKE CHAMBER AND RESULT IN INJURY.

- A. Check the amount of push rod travel. Maximum should not exceed 2" for Type 30 chambers and 1¾" for Type 24 chambers.
 - 1) Optimum push rod travel on a green brake* should be under 2".
 - 2) Optimum push rod travel on a burnished or broken-in brake should be under 1¾".

- B. With air pressure applied to brakes, check for lining to drum contact. The contact should approach 100%. Use a .010" feeler gauge if in doubt. It should not fit between the lining and drum during brake application.
 - C. Check to ensure the lining is inside the drum during application. More than .06" hanging out of the drum is not recommended.
4. Release air pressure from the brakes and confirm that all brakes release to the normal relaxed position.

***Note:** A “green brake” is an unground, unburnished brake. Normal manufacturing tolerances dictate that there is a break-in period required after which the lining will seat into a perfect concentric situation. During this break-in period, the user must be aware that additional brake adjustments will be mandatory to achieve optimum braking performance.





Recommended Brake Assembly/Disassembly Procedure

Although Dexter Axle supplies non-asbestos brake linings as standard equipment, asbestos linings may still be found on axles in service.

CAUTION

POTENTIAL ASBESTOS DUST HAZARD!

Some older brake linings may contain asbestos dust, which has been linked to serious or fatal illnesses.

Certain precautions need to be taken when servicing brakes:

1. Avoid creating or breathing dust.
2. Avoid machining, filing or grinding the brake linings.
3. Do not use compressed air or dry brushing for cleaning (dust can be removed with a damp brush).

Assembly/Disassembly Procedure **16½" x 7" Brakes**

Disassembly

1. Block and secure trailer on adequate capacity jack stands. Follow trailer manufacturers recommendations for lifting and supporting the unit. Check that the wheel and drum rotate freely.
2. Release brake and back off slack adjuster.
3. Remove wheel equipment.
4. Remove slack adjuster lock ring and slack adjuster.
5. Remove brake drum (if outboard mount). Remove hub and drum assembly (if inboard mount).
6. Disengage the roller retainers from the rollers.
7. Press down on the bottom brake shoe and remove the lower cam roller. Lift the top shoe and take out the top cam roller.

8. Lift out the shoe retractor spring, which is now free of tension.
9. Swing the lower shoe back approximately 180° to relieve the tension on the shoe keeper springs. Remove the springs and slip the shoes off the anchor pins.
10. Remove camshaft lock ring, spacer washer(s) and camshaft.
11. After removing the shoes, completely inspect all brake components, servicing as necessary.

Reassembly

1. Install new anchor pin bushings, camshaft bushing and camshaft seals into the spider.
2. Install cam roller, retainer clip and retractor spring retainers onto the brake shoes.
3. Install 1/8" thick camshaft washer onto the camshaft.
4. Install the cam shaft into the spider. Install spacer washer and lock ring retainer on camshaft before sliding the camshaft through the camshaft support bracket. Install the slack adjuster, washer and lock ring retainer.
5. Install the brake keeper springs onto the shoes. Install shoes onto the spider by placing shoes in place on the anchor pins, then "wrap" the two shoes into place about the spider.
6. Install the shoe retractor spring onto the shoes.
7. Connect slack adjuster to brake chamber pushrod.
8. Reinstall wheel equipment per manufacturers instructions.
9. Adjust brakes as outlined in brake adjustment procedures.

Note: Always use new springs when servicing brakes. Always use Dexter shoes when replacing shoes.





Assembly/Disassembly Procedure 12¼" x 7½" Brakes - P Style

Disassembly

1. Block and secure trailer on adequate capacity jack stands. Follow trailer manufacturers recommendations for lifting and supporting the unit. Check that the wheel and drum rotate freely.
2. Release brake and back off slack adjuster.
3. Remove wheel equipment.
4. Remove slack adjuster lock ring and slack adjuster.
5. Remove hub and drum assembly.
6. Remove anchor pin anti-rotation bolt (if applicable).
7. Remove anchor pin retainers and washers.
8. Remove anchor pins and brake shoes.
9. Remove brake return springs.
10. Remove camshaft lock ring, spacer washers(s) and cam shaft.
11. Remove roller pin retainers.
12. Remove roller pins, rollers from shoes.
13. Remove camshaft bushings and seals from spider.
14. After removing the shoes, completely inspect all brake components, servicing as necessary.

Reassembly

1. Install new camshaft bushing and camshaft seals into the spider.
2. Install cam roller assemblies onto the brake shoes.
3. Install "D" shaped camshaft washer onto the camshaft.
4. Install the camshaft into the spider. Install spacer washer and lock ring retainer on camshaft before sliding the camshaft through the camshaft support bracket. Install the slack adjuster, washer and lock ring retainer.

5. Install shoes, anchor pins and spacers onto spider. Install anchor lock rings.
6. Install retractor spring.
7. Tighten anchor pin anti-rotation screw (if applicable).
8. Connect slack adjuster to brake chamber pushrod.
9. Reinstall wheel equipment per manufacturers instructions.
10. Adjust brakes as outlined in brake adjustment procedures.

Note: Always use new springs when servicing brakes.
Always use Dexter shoes when replacing shoes.

Assembly/Disassembly Procedure ***12¼" x 7½" Brakes - PQ Style***

Disassembly

1. Block and secure trailer on adequate capacity jack stands. Follow trailer manufacturers recommendations for lifting and supporting the unit. Check that the wheel and drum rotate freely.
2. Release brake and back off slack adjuster.
3. Remove wheel equipment.
4. Lift top shoe upward to disengage the shoe webs from the anchor pin. Remove anchor pin.
5. Repeat procedure 4 for the bottom shoe.
6. Remove brake keeper springs.
7. Unwrap bottom shoe by pivoting the shoe on the camshaft head and twisting the shoe 90° under the spindle. Remove shoe assemblies from spider.
8. Remove slack adjuster lock ring, disconnect slack clevis, and then remove slack adjuster.
9. Remove camshaft lock ring, spacer washer(s) and camshaft.
10. Completely inspect all brake components, servicing as necessary.





Reassembly

1. Install new camshaft bushing. Ream bushing to 1.505/1.515 if required. Install camshaft seals into the spider.
2. Lubricate roller bore with anti-seize and install new cam roller assemblies onto the brake shoes.
Note: The head of roller pin should face the camshaft “D” washer once shoes are installed on spider.
3. Install “D” shaped camshaft washer onto the camshaft.
4. Install the camshaft into the spider. Install 005-075-00 washer and lock ring retainer on the camshaft before sliding the camshaft through the camshaft support bracket.
5. Install the slack adjuster and 005-134-00 washer and 069-078-00 lock ring retainer for 28 spline camshafts or 005-075-00 washer and 069-020-00 lock ring retainer for 10 spline camshafts.
6. Lubricate anchor pin notches with anti-seize lubricant.
7. Install “W” shaped retractor spring retainer pin into the 0.50” diameter shoe web holes near the camshaft roller end of the shoe.
8. Install retractor spring between shoes. Place top shoe onto spider as in service. Pivot bottom shoe on the camshaft head and twist the shoe 90° under the spindle, properly placing shoe on the spider as in service.
9. Install two (2) keeper springs on the anchor end of the shoes.
10. Lubricate anchor pin bores and shoe anchor pins with anti-seize lubricant.
11. Repeat procedure 10 for the bottom shoe.
12. Lift top shoe upwards to clear anchor pin hole. Install anchor pin.
13. Connect slack adjuster to brake chamber pushrod.
14. Lubricate cam bushings and slack adjuster.
15. Reinstall wheel equipment per manufacturers instructions.

16. Adjust brakes as outlined in brake adjustment procedures.

Note: Always use new springs when servicing brakes.
Always use Dexter shoes when replacing shoes.





Brake Component Lubrication

A schedule for the periodic lubrication of brake components should be established by the operator on the basis of past experience and severity of operation.

Lubrication Guidelines

For camshaft roller journals

Lubricate with high temperature anti-seize grease.

For anchor pins

Lubricate with high temperature anti-seize grease.

For manual slack adjusters

Lubricate with NLGI Grade 2.

For automatic slack adjusters

Lubricate with ASA manufacturers' recommended lubricant.

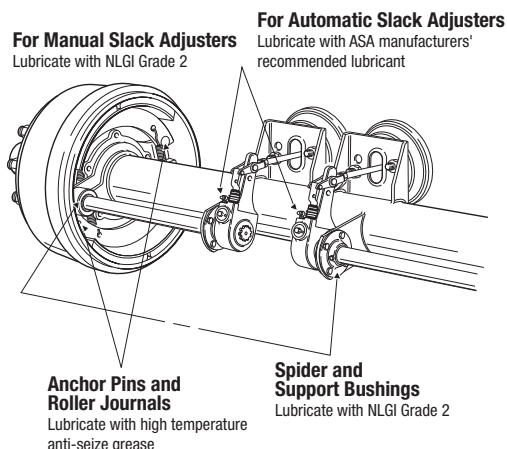

Frequency of Service

Camshaft roller journals, anchor pins, slack adjusters every 25,000 to 30,000 miles or every six months depending on severity of service. For off-highway use, service every 4 months depending on severity of service.

Note: Reline shoes or replace with new shoe and lining assemblies when the linings are grease saturated.

Suggested Preventative Maintenance

Every 1,000 Miles

Check oil level in wheel hub and inspect wheel for leaks.

Every 12,000 Miles

Check brake adjustment. Repack wheel bearings (grease application).

Every 25,000 to 30,000 Miles

Check lining wear and estimate reline time. Inspect camshaft, camshaft spider bushing, and camshaft support bracket bushing for any signs of wear.

Lubricate brake actuating components.

Every 100,000 Miles, Once a Year, or at Brake Reline

Replace wheel bearing lubricating oil (if applicable).

Check brake air chambers and slack adjusters. Inspect brake rollers, roller shafts, anchor pins and bushings, and replace if necessary.





Fastener Specifications

Part Name	Model	Size & Thread	Grade	Torque
Spindle Nut Inner (lg)	D2L__ D2M__	2 $\frac{5}{8}$ -16	5	Refer to Bearing Adj. Section 250-300 Ft. Lbs.
Outer (sm)	D2H__	2 $\frac{5}{8}$ -16	5	
Grease Zerk	Cam Bushing Spider	1/4-28 UNF 1/8-27 NPT	2 2	5-15 In. Lbs. 5-8 Ft. Lbs.
Cam Brackets	All Models	1/4-20	2	3-4 Ft. Lbs.
Air Chamber Mounting Nuts	All Models	5/8-11	5	Hex Nut 85-95 Ft. Lbs. Locknut 120-140 Ft. Lbs.
Anchor Pin Clamp Bolt	12 $\frac{1}{4}$ " Dia. Air Brakes	7/16-20	5	60-70 Ft. Lbs.
Dust Shield Mounting	16 $\frac{1}{2}$ " Dia. Air Brakes w/Tapped Spiders	5/16-18	5	10-15 Ft. Lbs.
Hub Cap	All Models	5/16-18	5	10-15 Ft. Lbs.
Drum Mounting Screw Backnut	12 $\frac{1}{4}$ " Dia. 16 $\frac{1}{2}$ " Dia.	5/8-18 3/4-16	5 5	160-180 Ft. Lbs. 175-200 Ft. Lbs.
Wheel Nut Inner	10 on 11 $\frac{1}{4}$ or	3/4-16	5 or 8 (steel) 8 (aluminum)	450-500 Ft. Lbs. 450-500 Ft. Lbs.
Outer	10 on 8 $\frac{3}{4}$	1 $\frac{1}{8}$ -16	5	
Flange Nuts	10 on 285.75 or 8 on 275mm	22mm x 1.5	10.9	450-500 Ft. Lbs.
Rim Mounting	Demountable Rim Type	3/4-10	5	Refer to Manf. Recommend.

Specifications

Replacement Parts/Kits

Brake Shoe Hardware Kits

Brake Size	Air (one brake)
12¼" x 7½" P Style	K71-098-00
12¼" x 7½" PQ Style	K71-460-00
16½" x 7" Q Style	K71-136-00

Brake Block Kits

Brake Size	Air (one brake)
12¼" x 7½" P and PQ Style	K71-133-00
16½" x 7" Q Style	K71-138-00

Camshaft Repair Kits

Brake Size	Air (one brake)
12¼" x 7½" P and PQ Style	K71-101-00
16½" x 7" Q Style	K71-135-00

Shoe & Block Assemblies

Brake Size	Part Number
12¼" x 7½" P Style	040-175-01
12¼" x 7½" PQ Style	040-320-01
16½" x 7" Q Style	040-180-00





Dexter Axle Limited Warranty

WHAT PRODUCTS ARE COVERED

All Dexter Axle Company (“Dexter Axle”) trailer axles, suspensions, and brake control systems excluding Dexter 6000 series Manufactured Housing Axles.

LIMITED 2 YEAR WARRANTY

Dexter Axle warrants to the original purchaser that its axles, suspension systems, and E/H hydraulic brake actuators shall be free from defects in material and workmanship for a period of two (2) years from the date of first sale of the trailer incorporating such components.

LIMITED 5 YEAR WARRANTY

Dexter Axle warrants to the original purchaser that its Nev-R-Lube® bearings and the suspension components only, of its Torflex® Axles shall be free from defects in material and workmanship for a period of five (5) years from the date of first sale of the trailer incorporating such components.

LIMITED 7 YEAR WARRANTY

Dexter Axle warrants to the original purchaser that its Predator Series® electric brake controllers shall be free from defects in material and workmanship for a period of seven (7) years from the date of purchase.

EXCLUSIVE REMEDY

Dexter Axle will, at its option, repair or replace the affected components of any defective axle, repair or replace the entire defective axle, or refund the then-current list price of the axle. In all cases, a reasonable time period must be allowed for warranty repairs to be completed. Allowance will only be made for installation costs specifically approved by Dexter Axle.

WHAT YOU MUST DO

In order to make a claim under these warranties:

1. You must be the original purchaser of the vehicle in which the spring suspension axles or Torflex® axles were originally installed.
2. You must promptly notify us within the warranty period of any defect, and provide us with the axle serial number and any substantiation which may include, but is not limited to, the return of part(s) that we may reasonably request.

3. The axles or suspensions must have been installed and maintained in accordance with good industry practice and any specific Dexter Axle recommendations, including those specified in Dexter Axle's publication "Operation Maintenance Service Manual."

EXCLUSIONS

These warranties do not extend to or do not cover defects caused by:

1. The connecting of brake wiring to the trailer wiring or trailer wiring to the towing vehicle wiring.
2. The attachment of the running gear to the frame.
3. Hub imbalance, or any damage caused thereby.
4. Parts not supplied by Dexter Axle.
5. Any damage whatever caused by or related to any alteration of the axle including welding supplemental brackets to the axle.
6. Use of an axle on a unit other than the unit to which it was originally mounted.
7. Normal wear and tear.
8. Alignment.
9. Improper installation.
10. Unreasonable use (including failure to provide reasonable and necessary maintenance as specified in Dexter Axle's publication "Operation Maintenance Service Manual" including required maintenance after "Prolonged Storage").
11. Improper wheel nut torque.
12. Cosmetic finish or corrosion.

LIMITATIONS

1. **In all cases, Dexter Axle reserves the right to fully satisfy its obligations under the Limited Warranties by refunding the then-current list price of the defective axle (or, if the axle has been discontinued, of the most nearly comparable current product).**
2. Dexter Axle reserves the right to furnish a substitute or replacement component or product in the event an axle or any component of the axle is discontinued or is otherwise unavailable.
3. These warranties are nontransferable.





GENERAL

THE FOREGOING WARRANTIES ARE EXCLUSIVE AND IN LIEU OF ALL OTHER WARRANTIES EXCEPT THAT OF TITLE, WHETHER WRITTEN, ORAL OR IMPLIED, IN FACT OR IN LAW (INCLUDING ANY WARRANTY OF MERCHANTABILITY OR FITNESS FOR A PARTICULAR PURPOSE).

These warranties give you specific legal rights, and you may also have other rights which vary from state to state.

DEXTER AXLE HEREBY EXCLUDES INCIDENTAL AND CONSEQUENTIAL DAMAGES, INCLUDING LOSS OF TIME, INCONVENIENCE, LOSS OF USE, TOWING FEES, TELEPHONE CALLS OR COST OF MEALS, FOR ANY BREACH OF ANY EXPRESS OR IMPLIED WARRANTY.

Some states do not allow limitations on how long an implied warranty lasts, or the exclusion or limitation of incidental or consequential damages, so the above exclusion or limitation may not apply to you.

Inquiries regarding these warranties should be sent to:

Dexter Axle Company
P.O. Box 250
Elkhart, Indiana 46515

Axle Identification

In the unlikely event that you should require service assistance from Dexter Axle, please have the lot (serial) number of the axle available when you call.

On all axles produced after April 2001, this nine digit number can be found near the center on the rear side of the axle beam. Look for the words DEXTER AXLE and the lot number will be located directly under the name. For easier identification, rubbing a piece of chalk over the number may help bring out the engraving.



Dexter Online Parts Store

From magnets and seals to complete brake and hub kits, Dexter offers a complete line of genuine replacement parts for your trailer. Most products are available in-stock and ready to ship within 24 hours direct to you from the factory. With dedicated customer support, quick turnaround and a 30-day money back guarantee, the Dexter Online Parts Store helps keep your trailer going.

- Hub Components
- Brake Components
- Suspension Components
- Complete Hub Kits
 - Brake Assemblies & Kits
 - Brake Controllers & Actuators



**Ready for Immediate Shipment
Direct to Your Door**

Visit us online at www.dexteraxle.com

Notes

Genuine Dexter axles and components are available nationwide from our plant locations listed below or through our network of distributors. Check our web site for the distributor nearest you.

Visit us online at www.dexteraxle.com

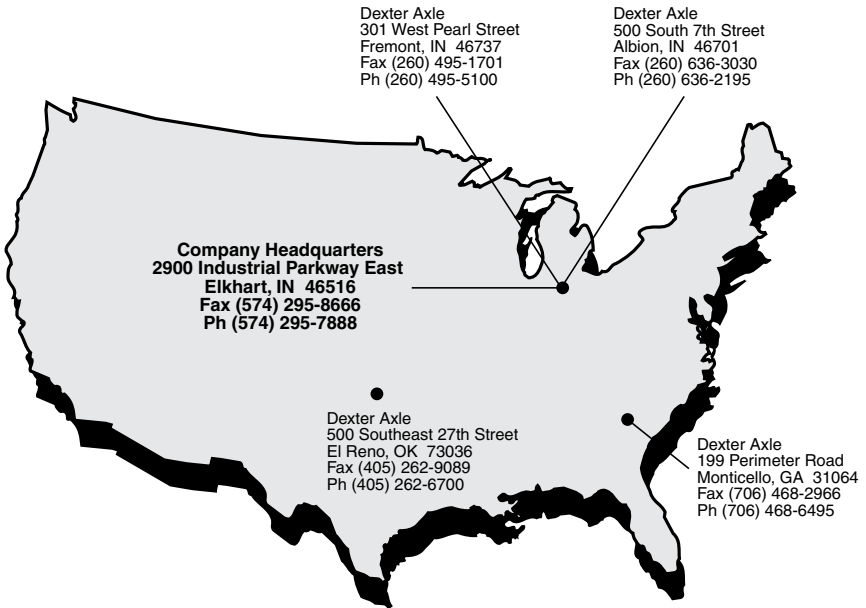

NO PART OF THIS CATALOG MAY BE REPRODUCED WITHOUT DEXTER AXLE'S PERMISSION.
ALL PART NUMBERS, DIMENSIONS AND SPECIFICATIONS IN THIS CATALOG ARE SUBJECT
TO CHANGE WITHOUT NOTICE.

GEARED FOR INNOVATION SINCE 1960



www.dexteraxle.com

2900 Industrial Parkway East ■ Elkhart, IN 46516

Phone: 574-295-7888 ■ Fax: 574-295-8666

