

<THESE INSTRUCTIONS MUST BE GIVEN TO THE END USER>



**B&W Trailer Hitches**

1216 Hawaii Rd / PO Box 186  
 Humboldt, KS 66748  
 P:620.473.3664  
 F:620.473.3766

**Companion™ Hitch Installation Instructions**

**20,000 LBS. TRAILER WEIGHT**  
**5,000 LBS. TRAILER TONGUE WEIGHT**

Call or Email us for Installation Support  
 hitches@turnoverball.com [www.turnoverball.com](http://www.turnoverball.com)

**Model 3500**

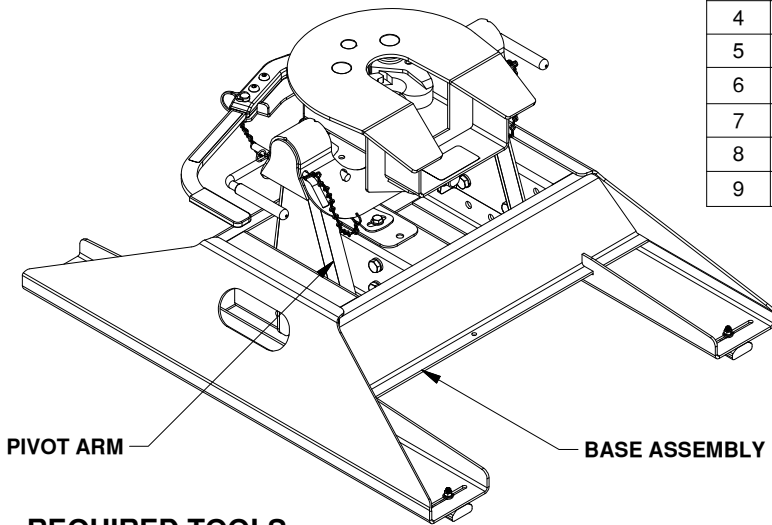

PARTS LIST			PARTS LIST		
ITEM	DESCRIPTION	QTY	ITEM	DESCRIPTION	QTY
1	1/2" X 1 1/2" Hex Cap Screws	16	10	1/4" Flat Washer	4
2	1/2" Split Lock Washers	16	11	1/4" Lock Washer	4
3	1/2" Threaded block	4	12	Plastic Foot Pads	2
4	Pivot Arm A	1	13	3/8" Button Head Cap Screw	2
5	Pivot Arm B	1	14	3/8" Lock Nut	2
6	1/2" X 3" Hex Cap Screw	1	15	Wire Torsion Spring	1
7	Socket Post	1	16	Mounting Clip	1
8	1/4" X 1 1/2" Machine Screw	4	17	1/4" X 1/2" Cap Screw	1
9	1/4" Finish Nut	5	18	1/4" Nylon Lock Nut	1

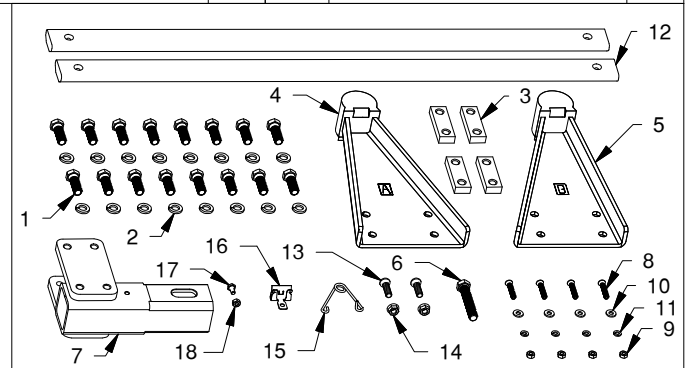

**REQUIRED TOOLS**

Installation of the Companion hitch requires a large torque wrench capable of measuring 80 ft-lbs, a 3/4" socket, and a 7/16" socket or wrench

**WARNING**

**Failure to comply with the safety information in these instructions could result in serious injury or death.**

- ⚠ Read all installation and operating instructions along with all labels before using this product.
- ⚠ Do not exceed tow or tongue rating of coupler, tow or tongue rating of hitch, or tow or weight ratings of truck or trailer. See vehicle and trailer manufacturer information for ratings. Exceeding these ratings may cause damage to towing components or loss of attachment between the trailer and truck.
- ⚠ Without proper knowledge, towing can be a dangerous activity. Understand all the risks involved with towing before proceeding. For information on towing safety, see **"The Trailer Handbook: A guide to Understanding Trailer and Towing Safety"** from the *National Association of Trailer Manufacturers*, [www.NATM.com](http://www.NATM.com).
- ⚠ Adding components to the chassis of any vehicle can be hazardous. There is potential for damage to vehicle, injury from tool usage and many other hazards. This installation must be completed by someone who is aware of the hazards involved. This person must be knowledgeable of proper safety procedures for a vehicle installation of this nature, and for usage of the equipment required to perform the installation.
- ⚠ Do not modify this product in any manner. Doing so could alter its integrity and lead to a loss of attachment between the trailer and the tow vehicle.
- ⚠ Regularly check that all bolted connections are at the correct torque specification. A visual inspection should be performed before each time you tow.

# PREPARING TO INSTALL

**⚠ WARNING:** Components of the Companion hitch are heavy and cumbersome to handle. Failure to use proper lifting techniques when moving and handling these parts could result in property damage or serious injury.

Locate the two plastic foot pads. Each pad attaches to the base through a slot at the end of the base leg. Before attachment, check the width of your bed rib by setting the wide face the plastic foot in a bed rib, see figure A1. If the plastic foot does not reach to the bottom of the bed rib trough, turn the plastic foot over, see figure A2 & A3. Locate four 1/4" machine screws, 1/4" flat washers, 1/4" lock washers and 1/4" finish nuts. Insert the machine screw up through the bottom of the foot pad through the slot and attach it with a 1/4" flat washer, 1/4" lock washer and a 1/4" finish nut, see figure A3. Do not tighten hardware at this time, so that the plastic foot is able to move back and forth in the slot.

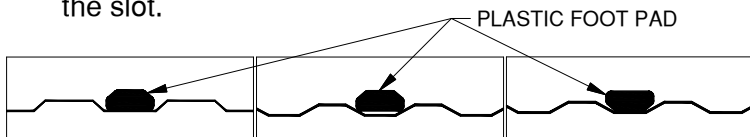

FIGURE A1: Wide rib orientation. FIGURE A2: Incorrect orientation. FIGURE A3: Narrow rib orientation.

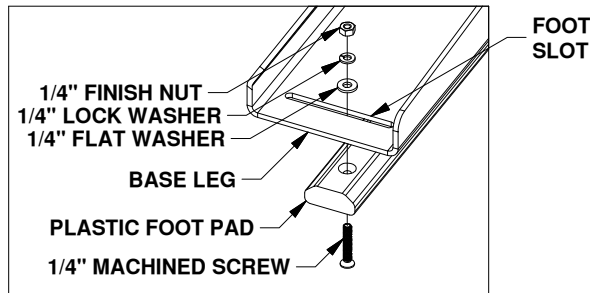

FIGURE A4, Plastic foot pad installation.

## NOTICE: Nissan Titan trucks:

Due to the configuration of the bed ribs on Nissan Titan trucks, it will be necessary for the foot pad to be installed on top of a bed rib, see figure A5.

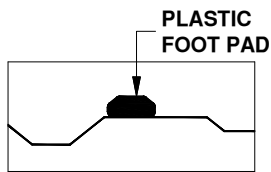

FIGURE A5: Titan rib configuration.

# INSTALL SOCKET POST

**NOTICE:** If the Companion is to be used in conjunction with a 1257 or 1309 model gooseneck hitch, call the factory for a post that is compatible with these hitches.

1. The socket post of the Companion hitch is designed to have two mounting options. In most truck models, the gooseneck socket will be forward of the axle and the companion socket post will install towards the cab of the truck (position 1). If your socket is located over the axle due to the frame configuration of your truck, as it is in the 2013 RAM 3500 trucks, install your socket post so the post is towards the rear of the truck. (position 2), see figure B1.

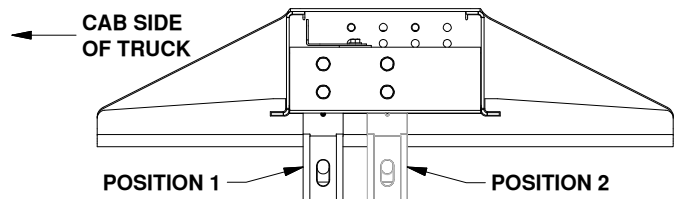

FIGURE B1: Cutaway view of Companion base with both socket post positions shown.

2. Once you have established in which orientation the socket post should be installed, locate the socket post and eight 1/2" cap screws and 1/2" lock washers. Slide the socket post into the bottom of the Companion base and attach the socket post to the base with the eight 1/2" cap screws and lock washers. See figure B2. Do not fully tighten hardware at this time.

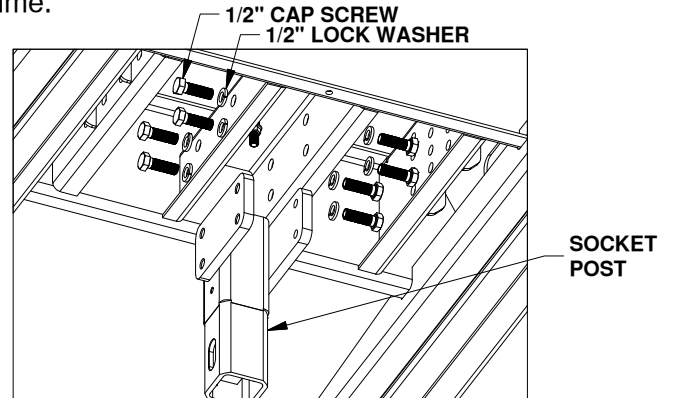

FIGURE B2: View of base looking up at the bottom.

3. Check that the spacer under the locking bracket is turned so that the hole in the spacer is positioned over the socket post. If adjustment is needed, use a tool, such as a screwdriver, to pry up and rotate the spacer. Install the 1/2" x 3" cap screw (draw down bolt) into the top of the Companion base, as shown in figure B3. Thread the cap screw into the socket adjuster and hand tighten until the bottom of the slot in the socket adjuster is even with the bottom of the slot in the post as shown in figure B4.

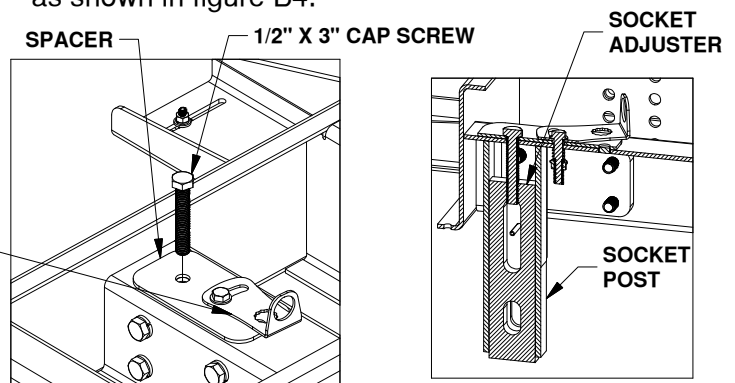

FIGURE B3: View of center of base

FIGURE B4: Cutaway view of center of base.

# INSTALL COMPANION BASE

**NOTICE:** If truck is equipped with a removable bed liner or mat, it should be removed or it must be cut to allow the base to directly connect with the bed. It is acceptable to install the RV base over a spray-in bed liner.

1. Check that the bed of the truck is clean, and that all debris is removed before beginning installation.

2. Locate the GN latch pin handle of the Turnoverball™ Gooseneck Hitch in the driver's side fender well. Retract the GN latch pin handle all the way to disengage the pin from ball. Remove the Turnoverball from the GN hitch receiver socket.
3. Carefully lift and position the Companion base into the GN hitch socket in the back of the truck bed. Orient the base so that the large warning label and the socket post are on or facing the cab side of the truck.
4. Square the Companion base legs with the ribs of the truck. Position the plastic pads so that they are both in line with the rib along their entire length. Tighten the four 1/4" nuts holding the pads to the base.
5. Re-engage the GN latch pin handle in the driver side fender.

**⚠ WARNING:** Check the latch pin under the truck. Make sure that the latch pin has passed through both sides of the socket and that the pin is covered up inside the socket by the socket adjuster, see figure C1.

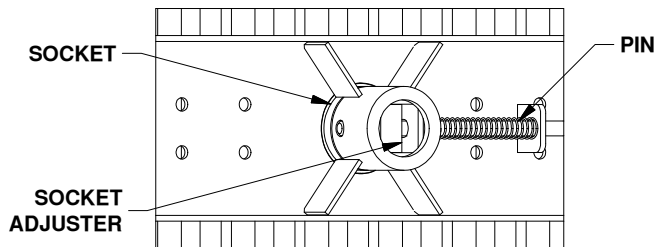

FIGURE C1: Typical view of Turnoverball gooseneck center under bed.

6. Secure the base to the truck bed by **first** tightening the eight 1/2" cap screws attaching the socket post into the center of the base to 80 ft-lbs. **Second**, tighten the 1/2" x 3-1/2" draw-down bolt to 60 ft-lbs. Lock the draw down bolt in place by swiveling the locking bracket over the draw down bolt, see figure C2.

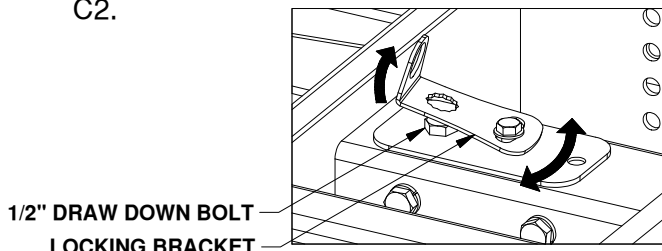

FIGURE C2: View of top of base.

**NOTICE:** DO NOT lubricate the draw down bolt, the torque value is for dry threads only.

**NOTICE:** Failure to "lock" the draw down bolt with the locking bracket will allow the draw-down bolt to loosen. Property damage may result when the base is not properly clamped to the truckbed.

## INSTALL PIVOT ARMS

1. Mount the pivot arms using one of the nine different locations illustrated in Table D1. These nine locations allow flexibility in coupler height (vertical adjustment) and distance from the cab (horizontal adjustment). Choose a location so that your trailer will be as level as possible and have adequate turning clearance while towing. **See warnings after step 2.**

TABLE D1: Pivot arm position table

		HORIZONTAL ADJUSTMENT		
		Kingpin 3" behind post	Kingpin 5" behind post	Kingpin 7" behind post
POSITION 1				
POSITION 2		Kingpin 1" ahead of post	Kingpin 1" behind post	Kingpin 3" behind post
VERTICAL ADJUSTMENT	HIGHEST POSITIONS (18 1/4")			
	MEDIUM HEIGHT POSITIONS (17 1/4")			
	LOWEST POSITIONS (16 1/4")			

POSITION 2

2. Locate both pivot arms, the four 1/2" threaded blocks, eight 1/2" cap screws, and eight 1/2" split lock washers. Place the lock washers over the cap screws. Align the flat side of the pivot arm flat against the bolt plate and install four 1/2" cap screws through the holes on the arm, holding the arm in place. The holes on one side of the threaded block have a tapered edge for starting screws. Pass the threaded blocks through the leg and align the blocks with each set of screws and start each screw, see figure D2. After all screws are started through the arms, torque each bolt to 80 ft-lbs.

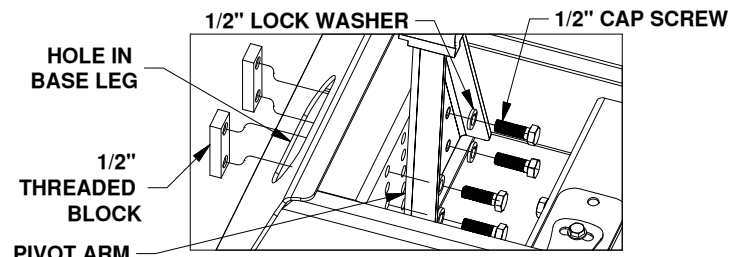
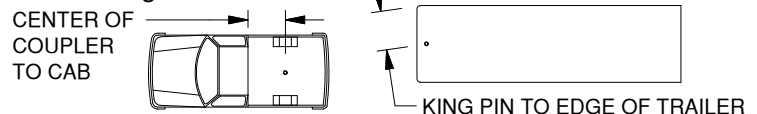

FIGURE D2: View looking at passenger pivot arm mounting location.

- ⚠ WARNING:** B&W recommends that you check the clearance between the truck cab and the trailer. Compare the measurement taken from the center of the Coupler to the cab, to the measurement taken from the center of the king pin to the farthest forward corner point of the trailer. These measurements will allow you to see how much clearance you will have between the cab and the trailer while towing and turning.



- ⚠ WARNING:** B&W also recommends that you check the clearance between the bed side and the underside of the front of the trailer and to allow adequate clearance for the pitch and roll of the trailer while towing.

# INSTALL LEVELING KIT

1. Locate the 1/4" cap screw and nut, along with the wire tension spring and mounting clip. Pass the 1/4" cap screw through the mounting clip and the wire spring as shown in figure E1. Thread the 1/4" lock nut onto the 1/4" cap screw. Tighten the lock nut just enough that the spring will stay in place but will still be able to rotate around the bolt if needed, see figure E2.

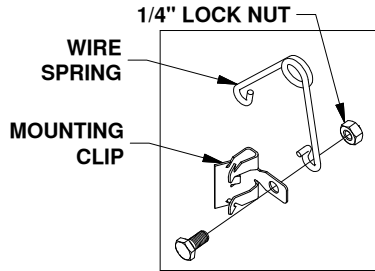

FIGURE E1:  
Leveling kit parts.

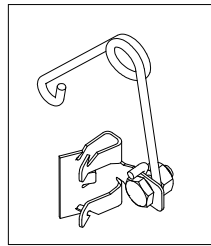

FIGURE E2:  
Assembled leveling kit.

2. Locate the flange which will be closest to the truck cab on the driver side pivot arm, see figure E3. The clip should be placed so that when the springs coil is in the line with the edge of the arm there will be 1/2" of clearance between the bottom of the rubber bumper and the top of the spring, see figure E4. Drive the clip securely onto the flange with a hammer.

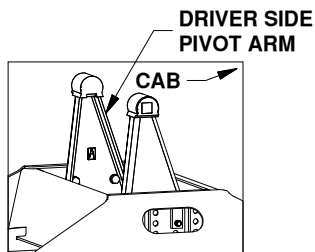

FIGURE E3:  
Base view.

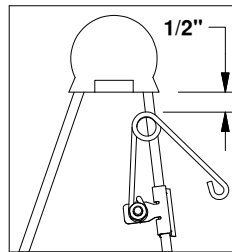

FIGURE E4: Driver  
side pivot arm.

# INSTALL COUPLER HANDLE

1. Locate the two 3/8" x 1-1/4" button head cap screws and the two 3/8" flanged lock nuts provided in a bolt bag. Pull out the coupler arm and pin it with the safety locking pin near the base of the arm as shown in figure F1.

**CAUTION:** Pulling the arm out away from the coupler creates a pinch point. Use caution when installing the handle to avoid injury.

Using the button cap screws and the lock nuts attach the coupler handle to the arm and tighten, see figure F1. Pull out the coupler cam handle safety pin.

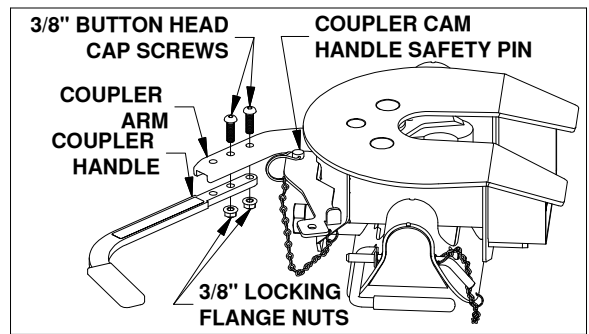

FIGURE F1: View looking down at side of coupler head.

# INSTALL COUPLER

Lubricate the polyurethane bushings on top of pivot arms with high grade lithium grease (available at your local hardware/automotive store). Place the coupler over the pivot arms. (The saddle handles should be parallel with the base in the latched position.) Place the saddle lock pins through the saddle, then insert the hairpins through the holes in the end of the saddle lock pins to secure the coupler to the pivot arms, see diagram G1.

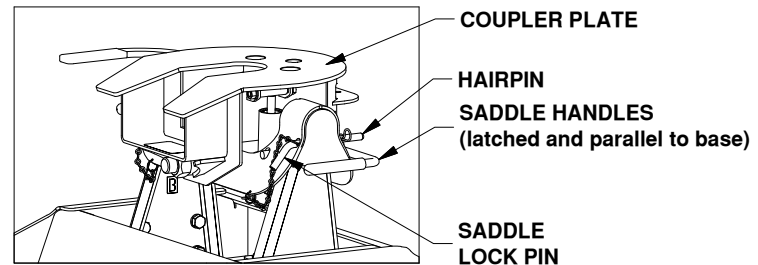

FIGURE G1:  
Coupler installed on base.

2. Adjust the resting angle of your coupler plate by rotating the spring on the driver side pivot arm. Pulling the top of the spring away from the cab will increase the angle of the coupler plate. Set the angle of the coupler so that head will tilt away from the cab when coupling, see figure G2. Tighten the 1/4" nut once the spring's orientation is set.

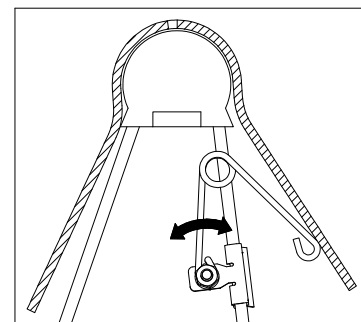

FIGURE G2: Cutaway view of  
driver side pivot arm and saddle.

# ATTACHING TRAILER

Remove the coupler cam handle safety pin and use the cam handle to open the coupler jaws. Adjust the height of the 5th wheel trailer so that the king pin plate is slightly lower than the top of the coupler. Back the truck towards the trailer, centering the trailer's king pin in the coupler, until the king pin has engaged the jaws. Ensure that the coupler cam handle has completely closed before inserting the cam handle safety pin through the cam handle and the coupler. Hook up brake and lighting connections before towing.

**⚠ WARNING:** Do not use the Companion 5th wheel hitch with any device that changes the location of the king pin pivot point. The king pin on your trailer must rotate in the jaws of the Companion Coupler, see figure H1. Preventing the king pin from rotating within the jaws of the Companion Coupler with a wedge, see figure H2, or any other device, such as a Reese Sidewinder® or Reese Revolution®, could result in property damage, serious injury or death.

Reese® is a registered trademark of Cequent Performance Products.

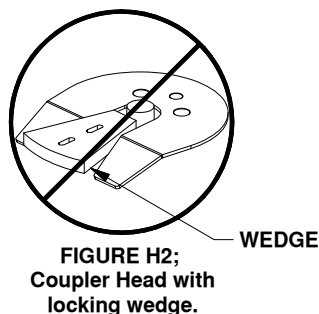
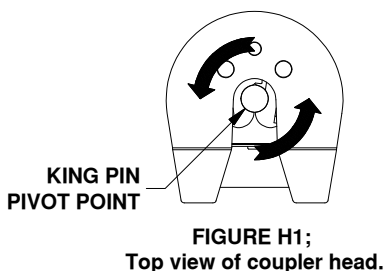

## HELPFUL TIPS:

- Approximately 15%-25% of the trailer weight should be on the hitch.
- The height of the king pin box and pivot arms should be adjusted so that the trailer is approximately level for towing.
- Allow adequate clearance between the bed side and the underside of the front of the trailer for pitch and roll of the trailer.
- Lubricate top surface of coupler with automotive type chassis grease or use a nylon lube plate to provide a lubricated surface.

# PULL TEST

Have the truck stationary with the emergency brake on, the trailer wheels blocked and landing gear still resting firm on the ground supporting the weight of the trailer. Make sure no one is between the truck and trailer, return to the cab of the truck. Release the emergency brake and apply the trailer brakes. Try to pull the trailer forward with the truck. If the trailer is properly hooked up, the wheel blocks and trailer brakes should not allow the truck to move forward. If trailer is not hitched correctly, the trailer will separate from the truck. However, with the landing gear resting firmly on the ground, it will support the trailer and not allow it to drop or fall on the truck sides.

# UNATTACHING TRAILER

Lower landing gear and block the trailer wheels. Raise the trailer until the tongue weight is removed from the truck. Then, unpin the Coupler handle and rotate to the open position to unlatch the jaws. If the jaws do not open, readjusting the landing gear may relieve pressure and allow them to open. Use the safety pin to lock the handle in the open position and when you are sure that the landing gear will support the trailer, move the truck forward to release the jaws from the kingpin. The jaws will always open when the pressure of the trailer is taken off the Coupler as the truck pulls away.

# UNINSTALL HITCH

To uninstall the Companion hitch, remove the Saddle lock pins, grab the saddle handles and lift to remove the Coupler from the pivot arms. To remove the Companion base, loosen the draw down bolt and retract the Turnoverball gooseneck latch pin handle all the way out. Carefully lift and position the Companion base out of the Gooseneck hitch socket.

**NOTICE:** All bolted connections should be checked for the correct torque specification regularly. Always perform a visual inspection before towing.

- The Companion was designed to be used with the Turnoverball™ mounting system. Other uses will void the warranty and are expressly prohibited by B&W Trailer Hitches.
- Grease jaws with automotive type chassis grease.
- Grease the saddle through the grease zerk approximately every six months with multi-purpose grease. this allows the coupler to pivot freely, see figure J1.

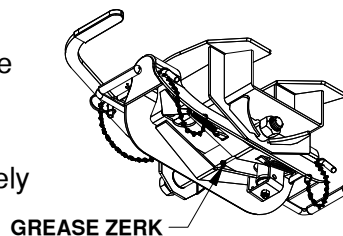

**FIGURE J1: Underside view of Coupler Head**

RVK3500 02 04 2014